

# TECHNICAL & SERVICE MANUAL

# SANYO

SAP-KRV9AEH + SAP-CRV9AEH  
SAP-KRV12AEH + SAP-CRV12AEH

FILE NO.

Destination: Europe

## DC INVERTER SPLIT SYSTEM AIR CONDITIONER

Indoor Model No.	Product Code No.
SAP-KRV9AEH	1 852 357 80
SAP-KRV12AEH	1 852 357 81

Outdoor Model No.	Product Code No.
SAP-CRV9AEH	1 852 357 84
SAP-CRV12AEH	1 852 357 85

Indoor Unit

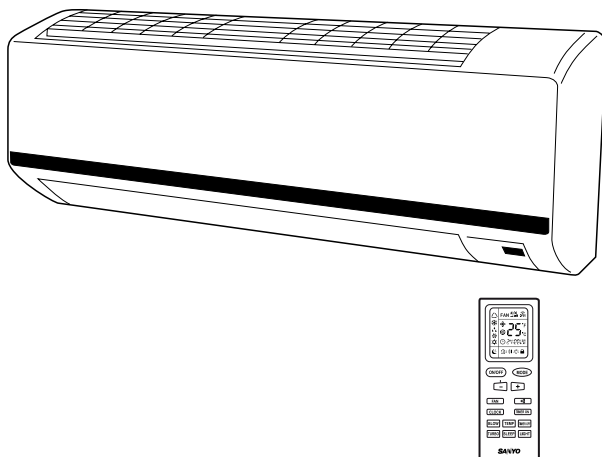

SAP-KRV9AEH  
SAP-KRV12AEH

Outdoor Unit

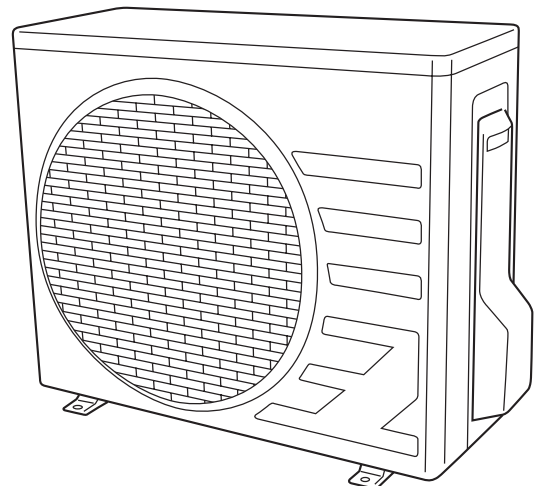

SAP-CRV9AEH  
SAP-CRV12AEH

### **RoHS**

- This product does not contain any hazardous substances prohibited by the **RoHS** Directive.

### **WARNING**

- You are requested to use **RoHS** compliant parts for maintenance or repair.
- You are requested to use lead-free solder.









## R410A















F-GAS REGULATION (EC) No 842 / 2006









Do not vent R410A into atmosphere : R410A is a fluorinated greenhouse gas, covered by Kyoto Protocol, with a Global Warming Potential (GWP) = 1975.













REFERENCE NO. SM0909902

## SAFETY PRECAUTIONS

- Before doing repair work, please read the " SAFETY PRECAUTIONS" carefully and fully understand them.
- The precautionary items here are divided into " Warning" and " Caution" items.  
Items in particular which may cause death or serious injury to the service personnel if the work is not performed correctly, are included in the " Warning" table.  
However, even precautionary items identified as " Caution" also have the potential for serious consequences if not performed correctly.  
Important safety precautions are described for all items in both categories. Be sure to carefully follow all of them.
- Symbol Indication
  -  : This symbol indicates items to which we need to pay attention.  
In this triangle, a definite precautionary item is described.
  -  : This symbol indicates the item to be prohibited.  
In or close to this circle, a prohibited item is described.
  -  : This symbol indicates the items requiring special attention or instruction.  
In or close to this circle, a prohibited item is described.
- After doing repair work, perform a test run to confirm that there are no abnormalities.  
At the same time, explain the precautions in use to the user.

 <b>Warning</b>	
Before performing an overhaul, disconnect the power plug or power cable from the unit. Performing the work with the power supplied to the unit, may cause an electric shock.	
When repair work or circuit inspection that requires power supply for the air conditioner, is to be performed, do not touch the charging section. Doing so may cause an electric shock.	 Prohibit
For the step-up capacitor attached to the electric section, perform the repair work after sufficiently discharging it. Insufficient capacitor discharge may cause an electric shock.	
Do not perform repair work on the electric sections with wet hands. Doing so may cause an electric shock.	 Prohibit
Do not start or stop the air conditioner by means of connecting or disconnecting the power plug. Doing so may cause an electric shock or fire.	 Prohibit
When conducting repair work only use components included in the parts list for the corresponding unit and perform the work with the appropriate tools. Incorrect or poor repair work may cause an electric shock or fire.	
Never modify the unit. Doing so may cause an electric shock or fire.	 Prohibit
Perform all electric work according to local applicable regulations related to electrical equipment or interior wiring regulation and make sure to use the exclusive circuit. Insufficient capacity to the electric circuit or defective arrangement results may cause an electric shock or fire.	
Make sure to replace any power cable or lead wire showing any signs of scratch or deterioration. Failure to do so may cause an electric shock, overheating or fire.	
Make sure that there is no dust on or slack in the power plug and insert fully into the socket. Dust or incomplete connections may cause an electric shock or fire.	
Do not damage or process the power cord, as it may cause an electric shock or fire.	 Prohibit
For the wiring between the indoor unit and outdoor unit, securely fix the specified cable onto the terminal plate. Poorly fixed wiring may cause a heat or fire.	
After connecting the wiring between the indoor unit and outdoor unit, attach the terminal cover securely. Incomplete attachment of the terminal cover may cause overheating or fire.	

 <b>Warning</b>	
If refrigerant gas blows off during the work, do not touch the refrigerant gas as it may cause frostbite.	 Prohibit
If refrigerant gas leaks during the work, ventilate the room. If refrigerant gas catches fire, harmful gas may be generated.	
Do not mix any gas other than the specified refrigerant gas in the refrigerating cycle. If air or other contaminants mix with the gas, pressure will become extremely high in the refrigerating cycle, which may cause a unit breakdown."	 Prohibit
When the welded section of the compressor intake or discharge pipe is to be disconnected, perform it in a well-ventilated place after sufficiently recovering the refrigerant gas. Any residue gas may jet out refrigerant or refrigerating machine oil, which may cause an injury.	
When the work is to be performed in a high place (About 2 meters or more), make sure to wear a safety helmet, gloves and safety belt. Insufficient safety gear may cause a serious injury in case of a fall.	
When the unit is to be relocated, confirm that the new installation location has sufficient strength for the weight of the unit. Insufficient strength of the installation location and incomplete installation work may cause an injury due to the unit falling.	
When the remote controller batteries are replaced, dispose of the old batteries out of the reach of children. If a child swallows a battery, make sure that the child gets immediate medical attention.	

 <b>Caution</b>	
Do not wash the air conditioner with water, as this may cause an electric shock or fire.	 Prohibit
For the repair work in places with high humidity or moisture, make sure to ground the unit. Failure to do so may cause an electric shock.	
Confirm that the component attachment position, wiring condition, soldering condition and connector connection are normal. If not, it may cause overheating or fire.	
Confirm that the temperature around the compressor is not too high, and then perform the repair work. Failure to do so may cause a burn.	
Perform welding work in a place with good ventilation. If the work is performed in a poorly ventilated area, it might cause a lack of oxygen.	
If the installation plate or attachment frame has deteriorated due to corrosion, etc., replace it. Failure to do so may cause an injury due to the unit falling.	
When the cleaning is to be performed, make sure to turn off the power and pull out the plug. Touching the fan that is rotating at high speed may result in an injury.	
When the indoor unit is to be removed, do not place it on an incline. Doing so may cause wet furniture because water left inside may trickle down.	 Prohibit
Do not hold the sharp end of the unit or the aluminum fins, as it may cause an injury to your hand or finger.	 Prohibit
After repairs, make sure to measure the insulation resistance and confirm that the value is 1 Mohm or more. Any insulation error may cause an electric shock.	
After repairs, make sure to check the drainage of the indoor unit. Inappropriate drainage may cause wet furniture and floors due to water leakage.	

# Table of Contents

	Page
<b>⚠ SAFETY PRECAUTIONS</b> .....	2
<b>TABLE OF CONTENTS</b> .....	4
<b>1. OPERATING RANGE</b> .....	6
<b>2. SPECIFICATIONS</b>	
2-1. Unit Specifications .....	7
2-2. Major Component Specifications .....	9
<b>3. DIMENSIONAL DATA</b> .....	13
<b>4. REFRIGERANT FLOW DIAGRAM</b>	
4-1. Refrigerant Flow Diagram .....	15
<b>5. PERFORMANCE DATA</b>	
5-1. Temperature charts .....	16
5-2. Air Throw Distance Charts .....	18
<b>6. ELECTRICAL DATA</b>	
6-1. Electrical Characteristics .....	20
6-2. Electric Wiring Diagrams .....	21
<b>7. FUNCTIONS</b>	
7-1. Main Functions .....	23
7-2. Control Specifications .....	29
<b>8. TROUBLESHOOTING</b>	
8-1. Precautions before Performing Inspection or Repair .....	34
8-2. Confirmation .....	34
8-3. Troubleshooting from Error Display .....	35
8-4. How to check the main part .....	37
<b>9. DISASSEMBLY PROCEDURE</b>	
9-1. Disassembly Procedure of Indoor Unit .....	44
9-2. Disassembly Procedure of Outdoor Unit .....	55

**10. REFRIGERANT R410A:****SPECIAL PRECAUTIONS WHEN SERVICING UNIT**

10-1. Characteristics of New Refrigerant R410A .....	60
10-2. Checklist before Servicing .....	60
10-3. Tools Specifically for R410A .....	62
10-4. Tubing Installation Procedures .....	62
10-5. In Case of Compressor Malfunction .....	63
10-6. In Case Refrigerant is Leaking .....	65
10-7. Charging Additional Refrigerant .....	66
10-8. Retro-Fitting Existing Systems .....	66
<b>APPENDIX A</b> INSTRUCTION MANUAL .....	A-1
<b>APPENDIX B</b> INSTALLATION INSTRUCTIONS.....	A-2

# 1. OPERATING RANGE

	Temperature	Indoor Air Intake Temp.	Outdoor Air Intake Temp.
Cooling	Maximum	32 °C D.B. / 23 °C W.B.	43 °C D.B. / 26 °C W.B.
	Minimum	21 °C D.B. / 15 °C W.B.	21 °C D.B.
Heating	Maximum	27 °C D.B.	24 °C D.B. / 18 °C W.B.
	Minimum	20 °C D.B.	-7 °C D.B. / -8 °C W.B.

## 2. SPECIFICATIONS

### 2-1. Unit Specifications

Indoor Unit **SAP-KRV9AEH**

Outdoor Unit **SAP-CRV9AEH**

<b>Power Source</b>		220 to 240V Single-Phase 50Hz	
<b>Voltage Rating</b>		230V	
<b>Performance</b>		Cooling	Heating
Capacity	kW	2.65 ( 1.0 to 3.3 )	3.5 ( 0.6 to 4.0 )
	BTU/h	9,000 ( 3,400 to 11,300 )	11,900 ( 2,000 to 13,600 )
Air Circulation (High)	Indoor / Outdoor	m <sup>3</sup> /h	520 / 1,600
Moisture Removal (High)		Liters/h	1.4
			-
<b>Electrical Rating</b>		Cooling	Heating
Available Voltage Range	V	198 to 264	
Running Amperes	A	4.1 ( 1.6 to 5.7 )	4.6 ( 1.0 to 6.5 )
Power Input	W	800 ( 290 to 1,200 )	970 ( 190 to 1,400 )
Power Factor	%	86	90
E.E.R.	W/W	3.31	-
C.O.P.	W/W	-	3.61
Compressor Locked Rotor Amperes	A	6.5	6.5
<b>Features</b>			
Controls / Temperature Control		Microprocessor / I.C. Thermistor	
Control Unit		Wireless Remote Control Unit	
Timer		24-hour Clock with ON/OFF Program Timer	
Fan Speeds	Indoor / Outdoor	Auto and 3 steps / 1 (Hi)	
Airflow Direction (Indoor)	Horizontal	Manual	
	Vertical	Auto	
Air Filter		Washable	
Compressor		DC Rotary (Inverter)	
Refrigerant / Amount charged at shipment	kg	R410A / 0.74	
Refrigerant Control		Capillary	
Operation Sound	Indoor : Hi/Me/Lo	dB-A	36 / 32 / 29
	Outdoor : Hi		
			36 / 32 / 29
			51
Refrigerant Tubing Connections		Flare Type	
Max. allowable tubing length at shipment	m	5.0	
Refrigerant	Narrow tube	mm (in.)	6.35 (1/4)
Tube Diameter	Wide tube	mm (in.)	9.52 (3/8)
<b>Dimensions &amp; Weight</b>		Indoor Unit	Outdoor Unit
Unit Dimensions	Height	mm	283
	Width	mm	770
	Depth	mm	201
Package Dimensions	Height	mm	261
	Width	mm	844
	Depth	mm	342
Weight	Net	kg	8.5
	Shipping	kg	11.0
Shipping Volume	m <sup>3</sup>	0.07	0.15

DATA SUBJECT TO CHANGE WITHOUT NOTICE.

**Remarks:** Rating conditions are:

Cooling: Indoor air temperature 27°C D.B. / 19°C W.B.

Outdoor air temperature 35°C D.B. / 24°C W.B.

Heating: Indoor air temperature 20°C D.B.

Outdoor air temperature 7°C D.B. / 6°C W.B.

Indoor Unit **SAP-KRV12AEH**  
 Outdoor Unit **SAP-CRV12AEH**

<b>Power Source</b>		220 to 240V Single-Phase 50Hz	
<b>Voltage Rating</b>		230V	
<b>Performance</b>		Cooling	Heating
Capacity	kW	3.53 (0.9 to 4.0)	4.1 (0.6 to 4.7)
	BTU/h	12,000 (3,100 to 13,600)	14,000 (2,000 to 16,000)
Air Circulation (High)	Indoor / Outdoor	m <sup>3</sup> /h	620 / 1,600
Moisture Removal (High)		Liters/h	2.0
			-
<b>Electrical Rating</b>		Cooling	Heating
Available Voltage Range	V	198 to 264	
Running Amperes	A	5.2 (1.5 to 6.9)	5.5 (1.1 to 6.6)
Power Input	W	1,100 (260 to 1,500)	1,135 (200 to 1,400)
Power Factor	%	95	95
E.E.R.	W/W	3.21	-
C.O.P.	W/W	-	3.61
Compressor Locked Rotor Amperes	A	6.5	6.5
<b>Features</b>			
Controls / Temperature Control		Microprocessor / I.C. Thermistor	
Control Unit		Wireless Remote Control Unit	
Timer		24-hour Clock with ON/OFF Program Timer	
Fan Speeds	Indoor / Outdoor	Auto and 3 steps / 1 (Hi)	
Airflow Direction (Indoor)	Horizontal	Manual	
	Vertical	Auto	
Air Filter		Washable	
Compressor		DC Rotary (Inverter)	
Refrigerant / Amount charged at shipment	kg	R410A / 0.96	
Refrigerant Control		Capillary	
Operation Sound	Indoor : Hi/Me/Lo	dB-A	38 / 34 / 29
	Outdoor : Hi		
			38 / 34 / 29
			51
Refrigerant Tubing Connections		Flare Type	
Max. allowable tubing length at shipment	m	5.0	
Refrigerant	Narrow tube	mm (in.)	6.35 (1/4)
Tube Diameter	Wide tube	mm (in.)	9.52 (3/8)
<b>Dimensions &amp; Weight</b>		Indoor Unit	Outdoor Unit
Unit Dimensions	Height	mm	283
	Width	mm	770
	Depth	mm	201
Package Dimensions	Height	mm	275
	Width	mm	592
	Depth	mm	771
Weight	Net	kg	342
	Shipping	kg	348
Shipping Volume	m <sup>3</sup>	0.07	0.15

DATA SUBJECT TO CHANGE WITHOUT NOTICE.

**Remarks:** Rating conditions are:

Cooling: Indoor air temperature 27°C D.B. / 19°C W.B.  
 Outdoor air temperature 35°C D.B. / 24°C W.B.  
 Heating: Indoor air temperature 20°C D.B.  
 Outdoor air temperature 7°C D.B. / 6°C W.B.



## 2-2. Major Component Specifications

### 2-2-1. Indoor Unit

Indoor Unit **SAP-KRV9AEH**

<b>Control PCB</b>		
Part No.		M819F2B110J
Controls		Microprocessor
Control Circuit Fuse		250V 3.15A
<b>Remote Control Unit</b>		
		YB1F2
<b>Fan</b>		
Type		Cross-Flow
Q'ty ... Dia. and Length	mm	1 ... D92 / L594
<b>Fan Motor</b>		
Type		AC Motor
Model ... Q'ty		FN10V-PG ... 1
No. of Poles		4
Rough Measure RPM (Cool / Heat)		1,100 / 1,140
Rated Power (Output Power)	W	10
Coil Resistance (Ambient Temp. 20 °C)	Ohm	Main : 386.4 Aux : 388.4
Safety Device	Type	Thermal protector
	Operating Temp. Open °C	100
	Close °C	75
Run Capacitor	Micro F	1.2
	VAC	500
<b>Flap Motor</b>		
Type		Stepping Motor
Model		MP24BA
Rating		DC 12V
Coil Resistance (Ambient Temp. 20 °C)	Ohm	Each Pair of Terminal : 200 +/- 8%
<b>Heat Exchanger Coil</b>		
Coil		Aluminum Plate Fin / Copper Tube
Rows		2
Fin Pitch	mm	1.4
Face Area	m <sup>2</sup>	0.179

DATA SUBJECT TO CHANGE WITHOUT NOTICE.

<b>Control PCB</b>			
Part No.			M819F2B111J
Controls			Microprocessor
Control Circuit Fuse			250V 3.15A
<b>Remote Control Unit</b>			YB1F2
<b>Fan</b>			
Type			Cross-Flow
Q'ty ... Dia. and Length	mm		1 ... D92 / L594
<b>Fan Motor</b>			
Type			AC Motor
Model ... Q'ty			FN10V-PG ... 1
No. of Poles			4
Rough Measure RPM (Cool / Heat)			1,150 / 1,190
Rated Power (Output Power)	W		10
Coil Resistance (Ambient Temp. 20 °C)	Ohm		Main : 386.4 Aux : 388.4
Safety Device	Type		Thermal protector
	Operating Temp.	Open °C	100
		Close °C	75
Run Capacitor	Micro F		1.2
	VAC		500
<b>Flap Motor</b>			
Type			Stepping Motor
Model			MP24BA
Rating			DC 12V
Coil Resistance (Ambient Temp. 20 °C)	Ohm		Each Pair of Terminal : 200 +/- 8%
<b>Heat Exchanger Coil</b>			
Coil			Aluminum Plate Fin / Copper Tube
Rows			2
Fin Pitch	mm		1.4
Face Area	m <sup>2</sup>		0.179

DATA SUBJECT TO CHANGE WITHOUT NOTICE.

## 2-2-2. Outdoor Unit

Outdoor Unit **SAP-CRV9AEH**

<b>Control PCB</b>	
Part No.	W819A102
Controls	Microprocessor
Control Circuit Fuse	250V 20A
<b>Compressor</b>	
Type	DC Rotary (Inverter)
Compressor Model / Nominal Output	1YC23AEXD / 600W
Compressor Oil ... Amount	CC FVC50K ... 375
Coil Resistance (Ambient Temp. 20 °C)	Ohm 1.764
Safety Device	
CT (Peak current cut-off control)	Yes
Compressor Discharge Temp. Control	Yes
Overload Relay	Model CS-7SA
	Operation Temp. Open 120 °C
Run Capacitor	Micro F -
	VAC -
Crankcase Heater	-
<b>Fan</b>	
Type	Propeller
Q'ty ... Dia.	mm 1 ... D370
<b>Fan Motor</b>	
Type	AC Motor
Model ... Q'ty	FW30N ... 1
No. of Poles	6
Rough Measure RPM (Cool / Heat)	930 / 930
Nominal Output	W 30
Coil Resistance	Ohm Main : 288.7
(Ambient Temp. 20 °C)	Aux : 188.3
Safety Device	Type Thermal protector
Operating Temp.	Open °C 135
	Close °C 95
Run Capacitor	Micro F 2.0
	VAC 450
<b>Heat Exchanger Coil</b>	
Coil	Aluminum Plate Fin / Copper Tube
Rows	1
Fin Pitch	mm 1.4
Face Area	m <sup>2</sup> 0.362
<b>External Finish</b>	
	Acrylic baked-on enamel finish

DATA SUBJECT TO CHANGE WITHOUT NOTICE.

Outdoor Unit **SAP-CRV12AEH**

<b>Control PCB</b>	
Part No.	W819A111
Controls	Microprocessor
Control Circuit Fuse	250V 20A

<b>Compressor</b>	
Type	DC Rotary (Inverter)
Compressor Model / Nominal Output	1YC23AEXD / 900W
Compressor Oil ... Amount	CC FVC50K ... 375
Coil Resistance (Ambient Temp. 20 °C)	Ohm 1.764
Safety Device	
CT (Peak current cut-off control)	Yes
Compressor Discharge Temp. Control	Yes
Overload Relay	Model CS-7SA
	Operation Temp. Open 120 °C
Run Capacitor	Micro F -
	VAC -
Crankcase Heater	-

<b>Fan</b>	
Type	Propeller
Q'ty ... Dia.	mm 1 ... D370

<b>Fan Motor</b>	
Type	AC Motor
Model ... Q'ty	FW30N ... 1
No. of Poles	6
Rough Measure RPM (Cool / Heat)	930 / 930
Nominal Output	W 30
Coil Resistance	Ohm Main : 288.7
(Ambient Temp. 20 °C)	Aux : 188.3
Safety Device	Type Thermal protector
Operating Temp.	Open °C 135
	Close °C 95
Run Capacitor	Micro F 2
	VAC 450

<b>Heat Exchanger Coil</b>	
Coil	Aluminum Plate Fin / Copper Tube
Rows	2
Fin Pitch	mm 1.4
Face Area	m <sup>2</sup> 0.357

  

<b>External Finish</b>	
	Acrylic baked-on enamel finish

DATA SUBJECT TO CHANGE WITHOUT NOTICE.

### 3. DIMENSIONAL DATA

Indoor Unit **SAP-KRV9AEH**  
**SAP-KRV12AEH**

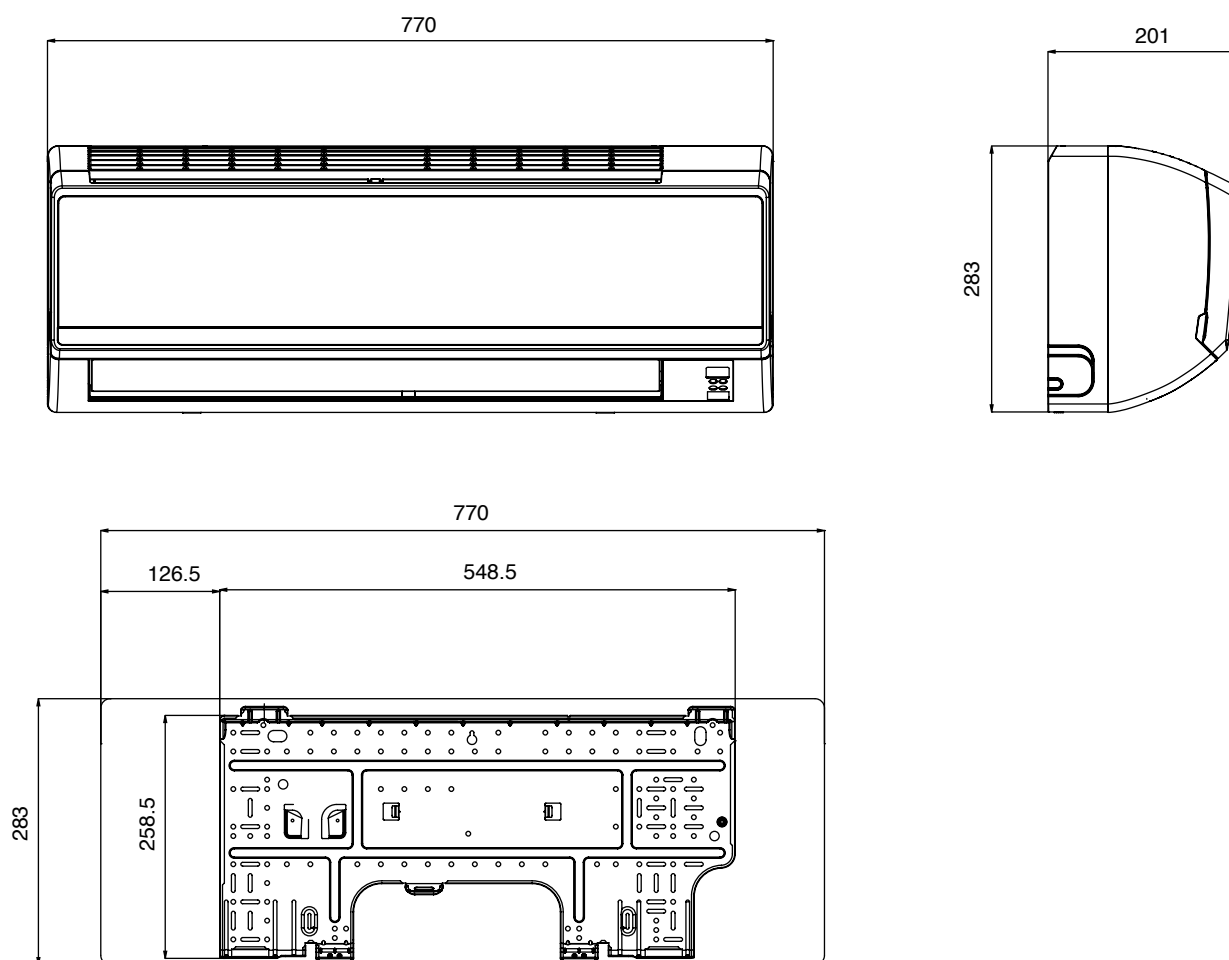

Outdoor Unit **SAP-CRV9AEH**  
**SAP-CRV12AEH**

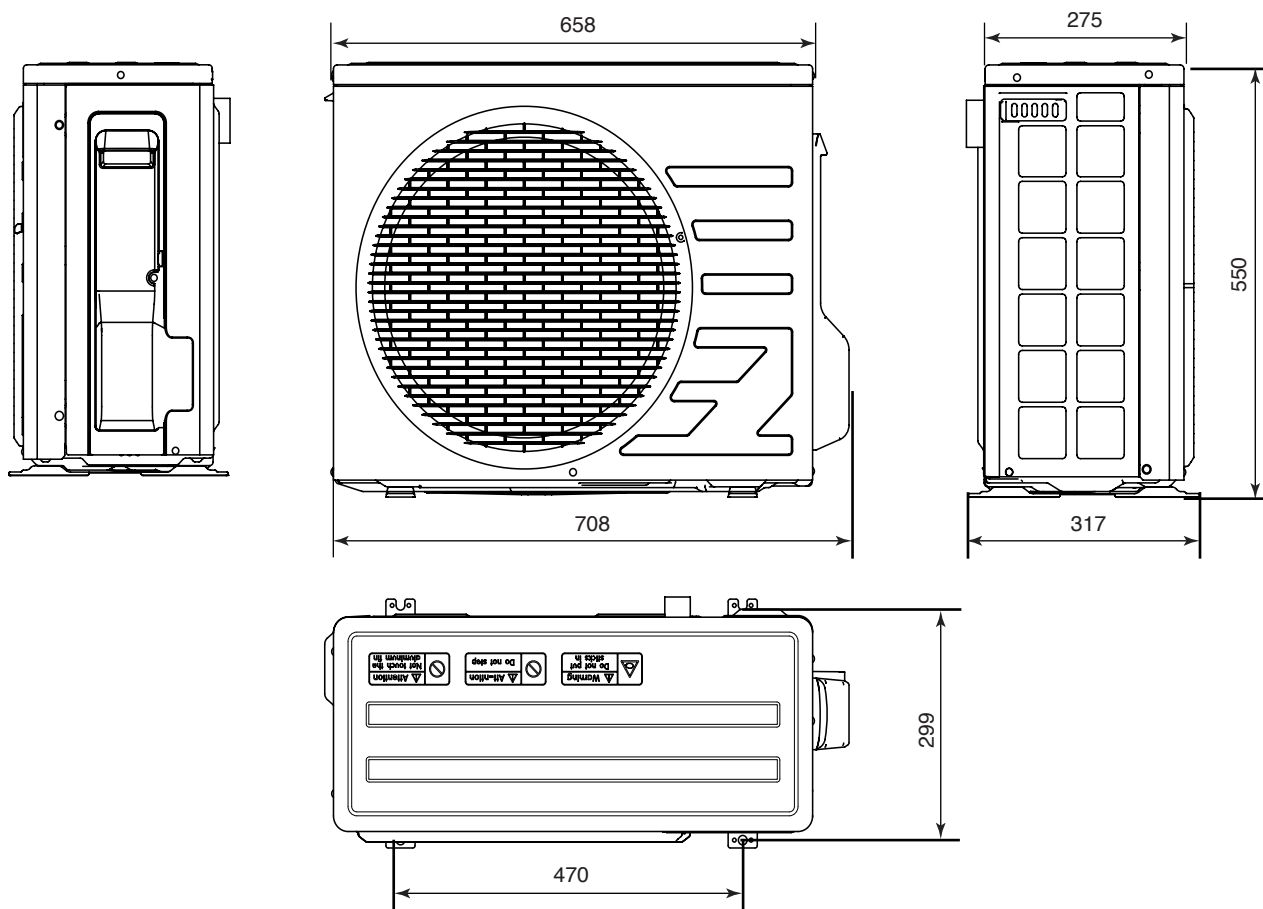

# 4. REFRIGERANT FLOW DIAGRAM

## 4-1. Refrigerant Flow Diagram

Indoor Unit **SAP-KRV9AEH**  
**SAP-KRV12AEH**

Outdoor Unit **SAP-CRV9AEH**  
**SAP-CRV12AEH**

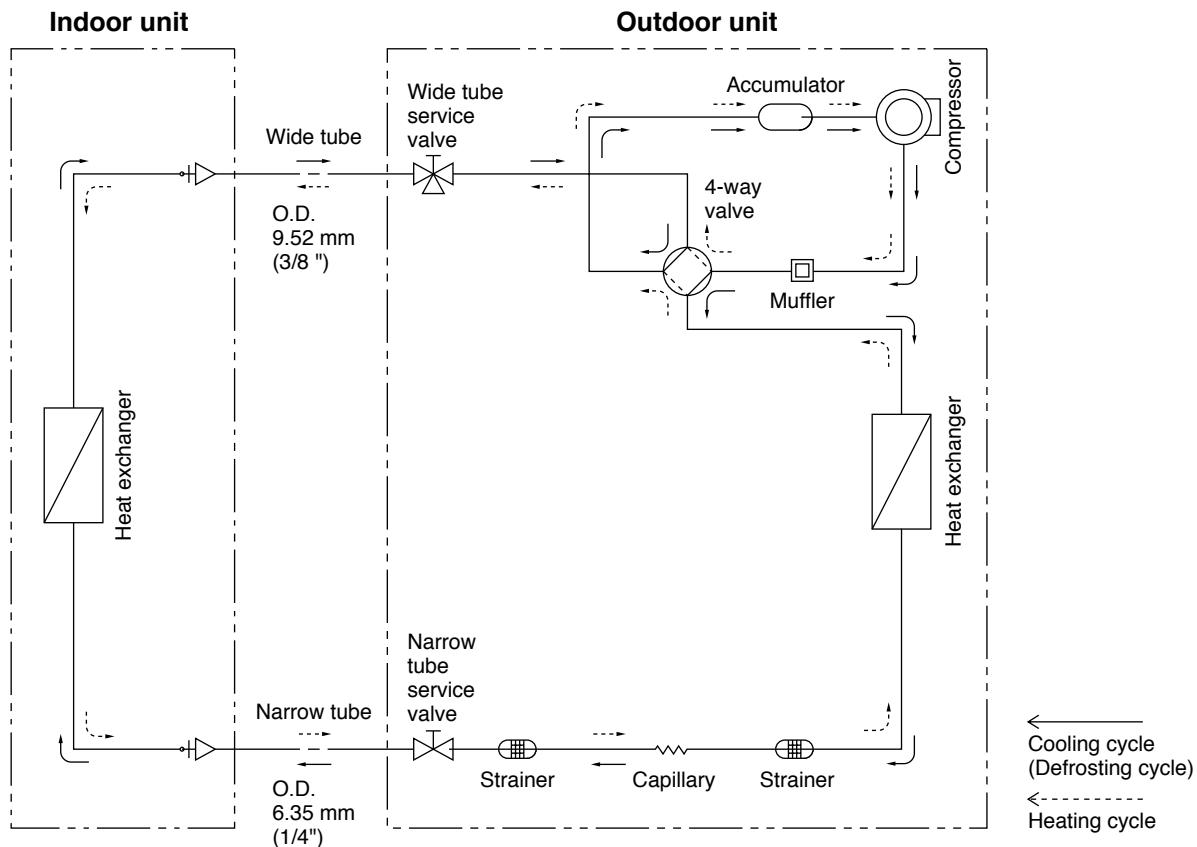

# 5. PERFORMANCE DATA

## 5-1. Temperature Charts

Indoor Unit **SAP-KRV9AEH**

Outdoor Unit **SAP-CRV9AEH**

### ■ Cooling Characteristics

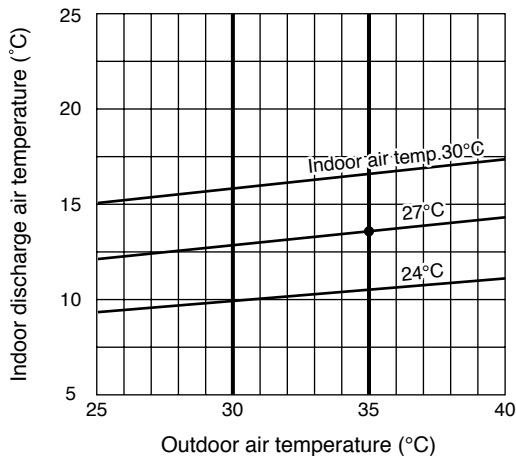
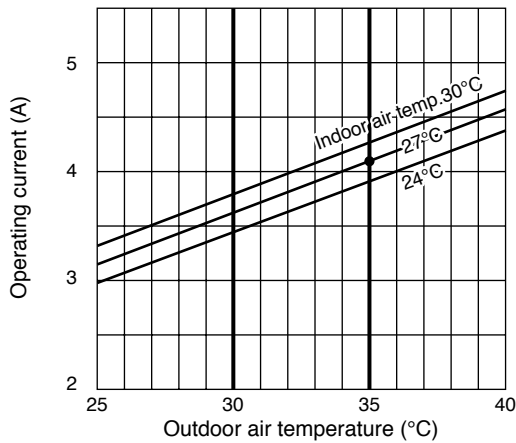
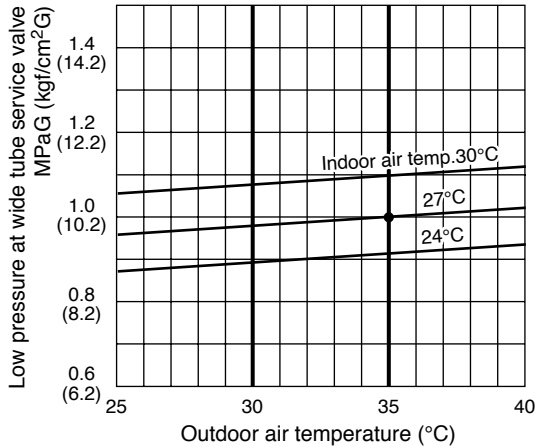

### ■ Heating Characteristics

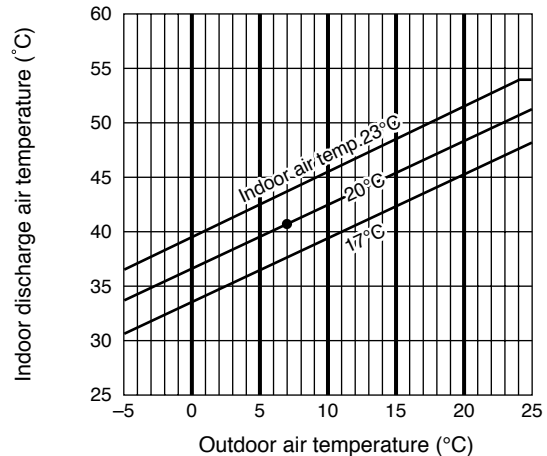
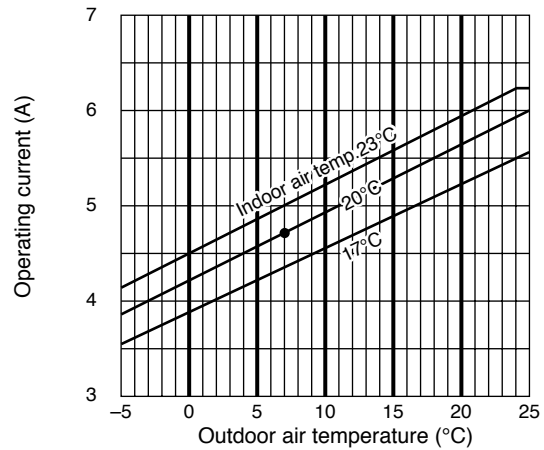
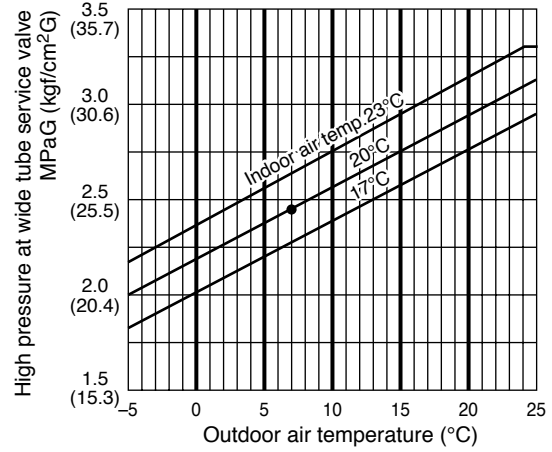

#### NOTE

- Check each performance value in test-run mode. Electrical performance values represent a combined indoor/outdoor value.
- Overload prevention operates to protect the air conditioner when outdoor ambient temperature becomes extremely high in heating mode. (Refer to "9-2. Overload prevention during heating.")

●:Points of rating condition

Black dots in above charts indicate the following rating conditions.

Cooling: Indoor air temperature 27 °C D.B. / 19 °C W.B.  
Outdoor air temperature 35 °C D.B. / 24 °C W.B.

Heating: Indoor air temperature 20 °C D.B.  
Outdoor air temperature 7 °C D.B. / 6 °C W.B.



Indoor Unit **SAP-KRV12AEH**

Outdoor Unit **SAP-CRV12AEH**

■ Cooling Characteristics

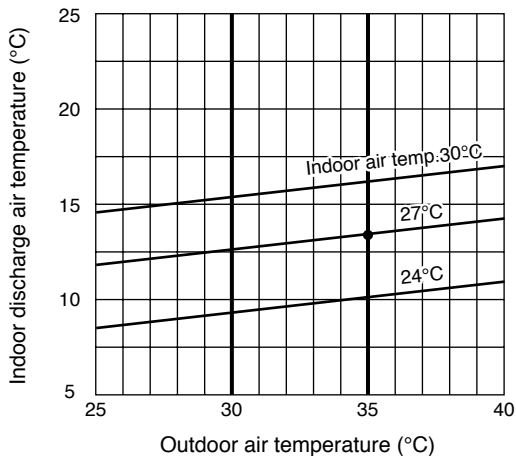
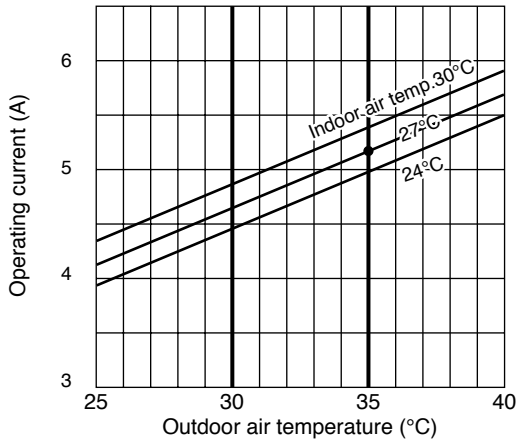
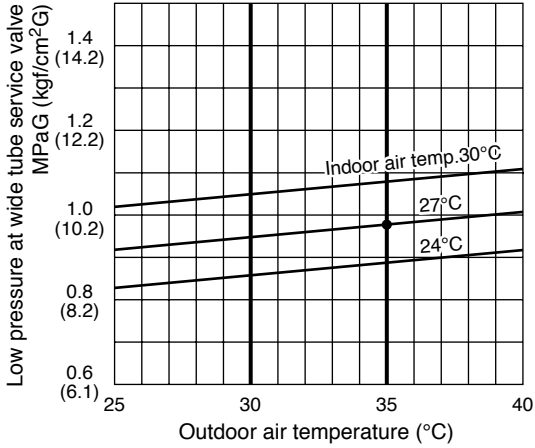

■ Heating Characteristics

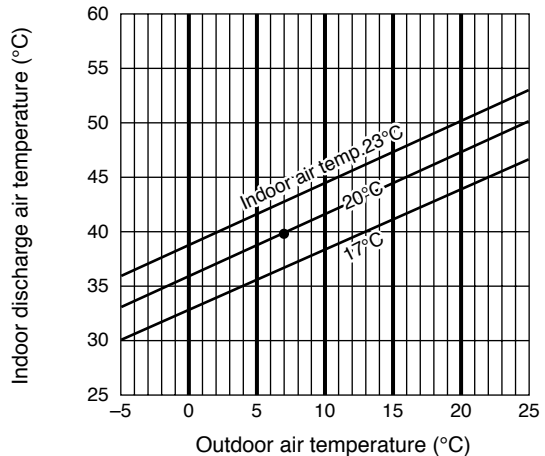
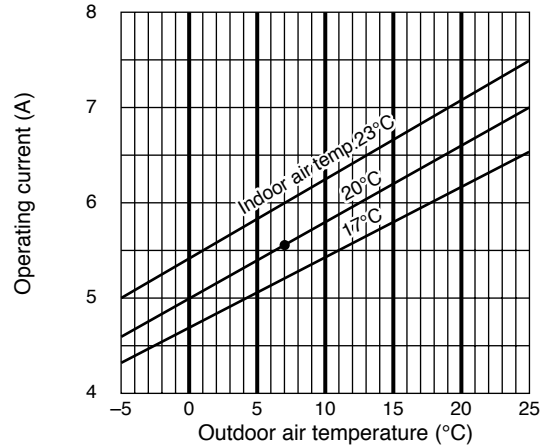
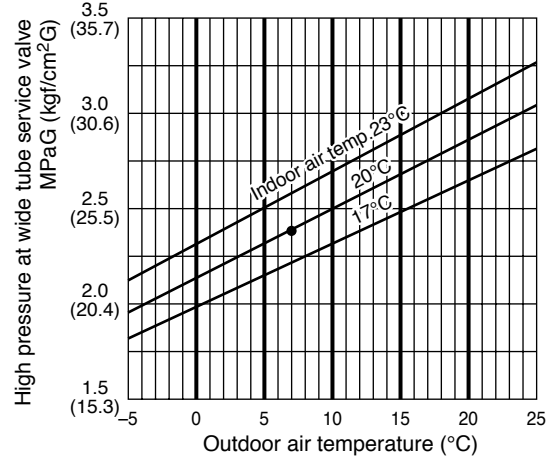

**NOTE**

- Check each performance value in test-run mode. Electrical performance values represent a combined indoor/outdoor value.
- Overload prevention operates to protect the air conditioner when outdoor ambient temperature becomes extremely high in heating mode. (Refer to "9-2. Overload prevention during heating.")

●:Points of rating condition

Black dots in above charts indicate the following rating conditions.

Cooling: Indoor air temperature 27 °C D.B. / 19 °C W.B.  
Outdoor air temperature 35 °C D.B. / 24 °C W.B.

Heating: Indoor air temperature 20 °C D.B.  
Outdoor air temperature 7 °C D.B. / 6 °C W.B.

## 5-2. Air Throw Distance Charts

Indoor Unit SAP-KRV9AEH

### Cooling

Room air temp. : 27°C

Fan speed : High

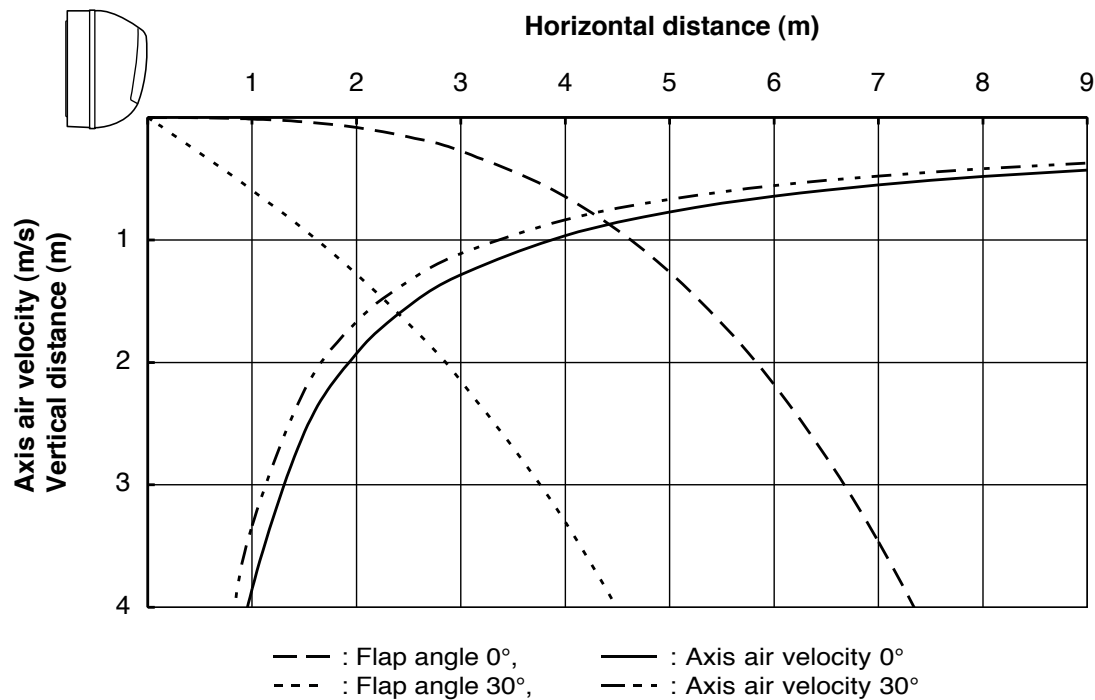

### Heating

Room air temp. : 20°C

Fan speed : High

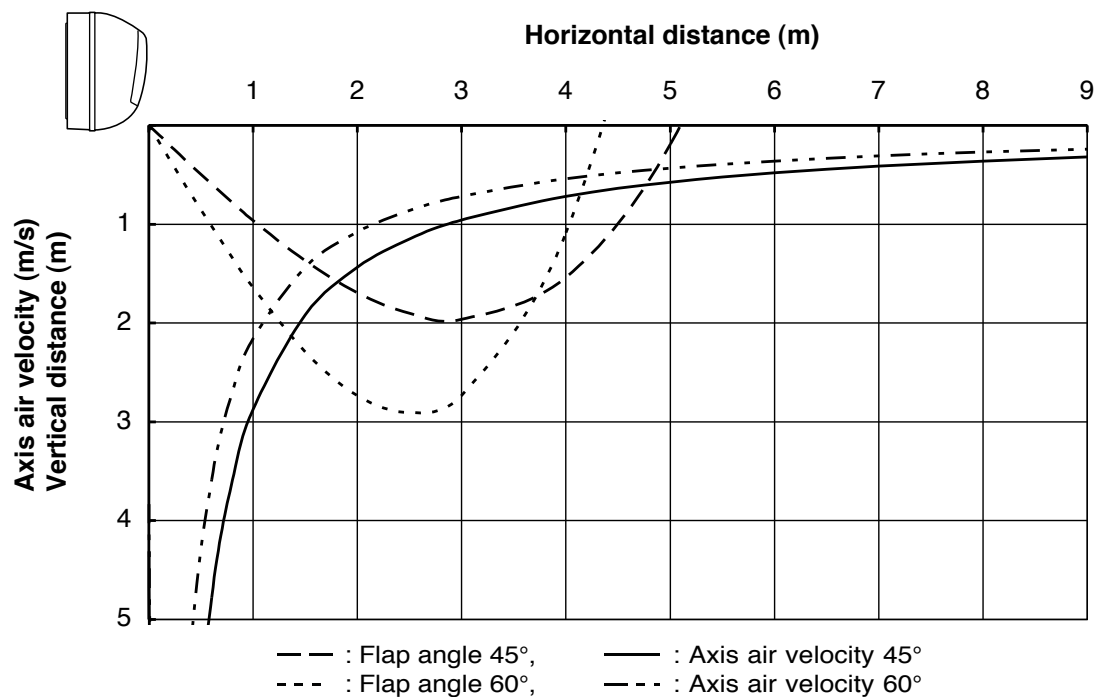

**Cooling**

Room air temp. : 27°C  
 Fan speed : High

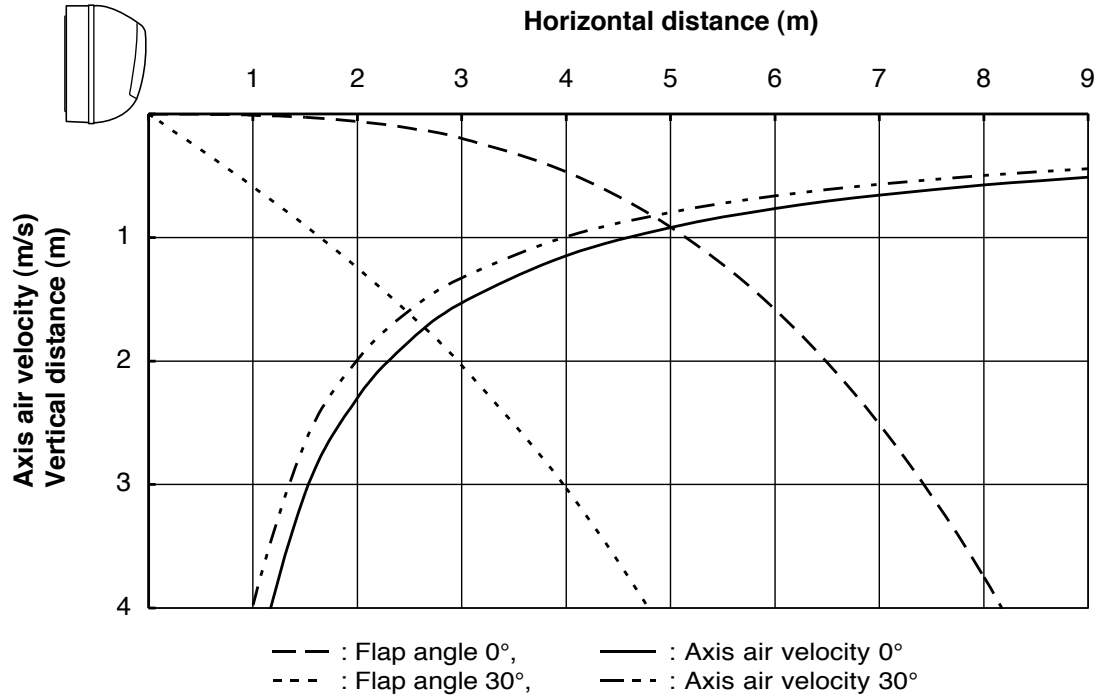

**Heating**

Room air temp. : 20°C  
 Fan speed : High

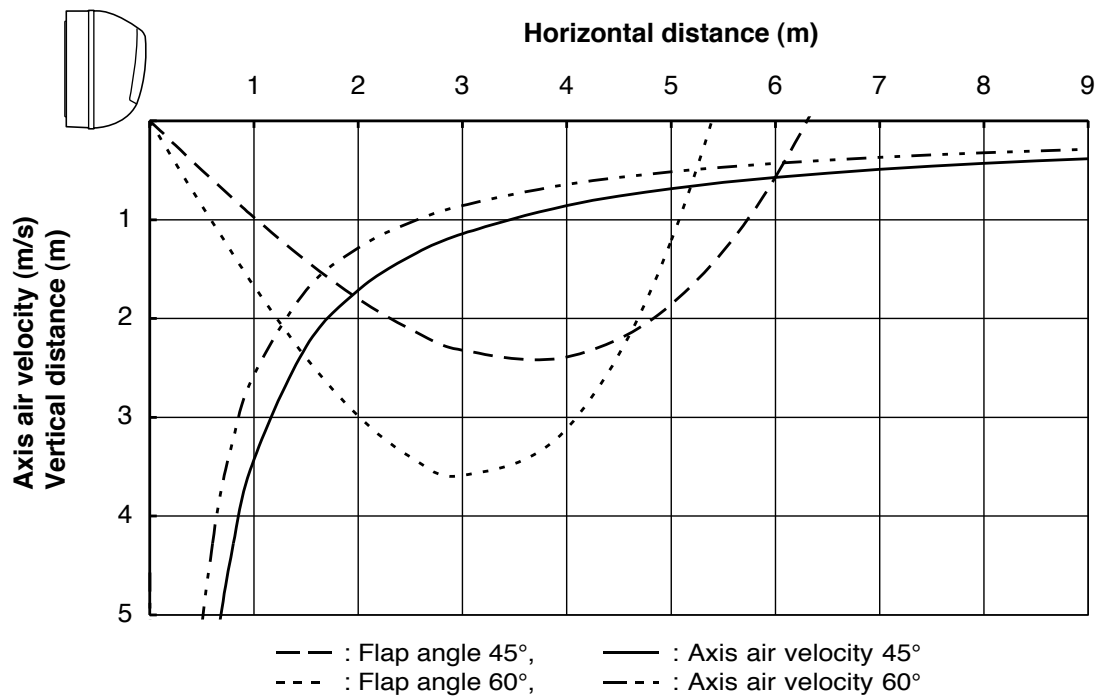

## 6. ELECTRICAL DATA

### 6-1. Electrical Characteristics

Indoor Unit **SAP-KRV9AEH**

Outdoor Unit **SAP-CRV9AEH**

#### Cooling

			Indoor Unit	Outdoor Unit	Complete Unit
			Fan Motor	Fan Motor + Compressor	
Performance at			230V Single-phase 50Hz		
Rating conditions	Running amp.	A	0.16	3.94	4.1
	Power input	W	48	752	800

Rating conditions: Indoor air temperature: 27 °C D.B. / 19 °C W.B.

Outdoor air temperature: 35 °C D.B.

#### Heating

			Indoor Unit	Outdoor Unit	Complete Unit
			Fan Motor	Fan Motor + Compressor	
Performance at			230V Single-phase 50Hz		
Rating conditions	Running amp.	A	0.16	4.44	4.6
	Power input	W	48	922	970

Rating conditions: Indoor air temperature 20 °C D.B.

Outdoor air temperature 7 °C D.B. / 6 °C W.B.

Indoor Unit **SAP-KRV12AEH**

Outdoor Unit **SAP-CRV12AEH**

#### Cooling

			Indoor Unit	Outdoor Unit	Complete Unit
			Fan Motor	Fan Motor + Compressor	
Performance at			230V Single-phase 50Hz		
Rating conditions	Running amp.	A	0.16	5.04	5.2
	Power input	W	49	1,051	1,100

Rating conditions: Indoor air temperature: 27 °C D.B. / 19 °C W.B.

Outdoor air temperature: 35 °C D.B.

#### Heating

			Indoor Unit	Outdoor Unit	Complete Unit
			Fan Motor	Fan Motor + Compressor	
Performance at			230V Single-phase 50Hz		
Rating conditions	Running amp.	A	0.16	5.34	5.5
	Power input	W	49	1,086	1,135

Rating conditions: Indoor air temperature 20 °C D.B.

Outdoor air temperature 7 °C D.B. / 6 °C W.B.

## 6-2. Electric Wiring Diagrams

Indoor Unit **SAP-KRV9AEH**  
**SAP-KRV12AEH**

Symbol	Color symbol	Symbol	Color symbol
<b>WH</b>	WHITE	<b>BN</b>	BROWN
<b>YE</b>	YELLOW	<b>BL</b>	BLUE
<b>RD</b>	RED	<b>BK</b>	BLACK
<b>YEGN</b>	YELLOW GREEN	$\oplus$	PROTECTIVE EARTH

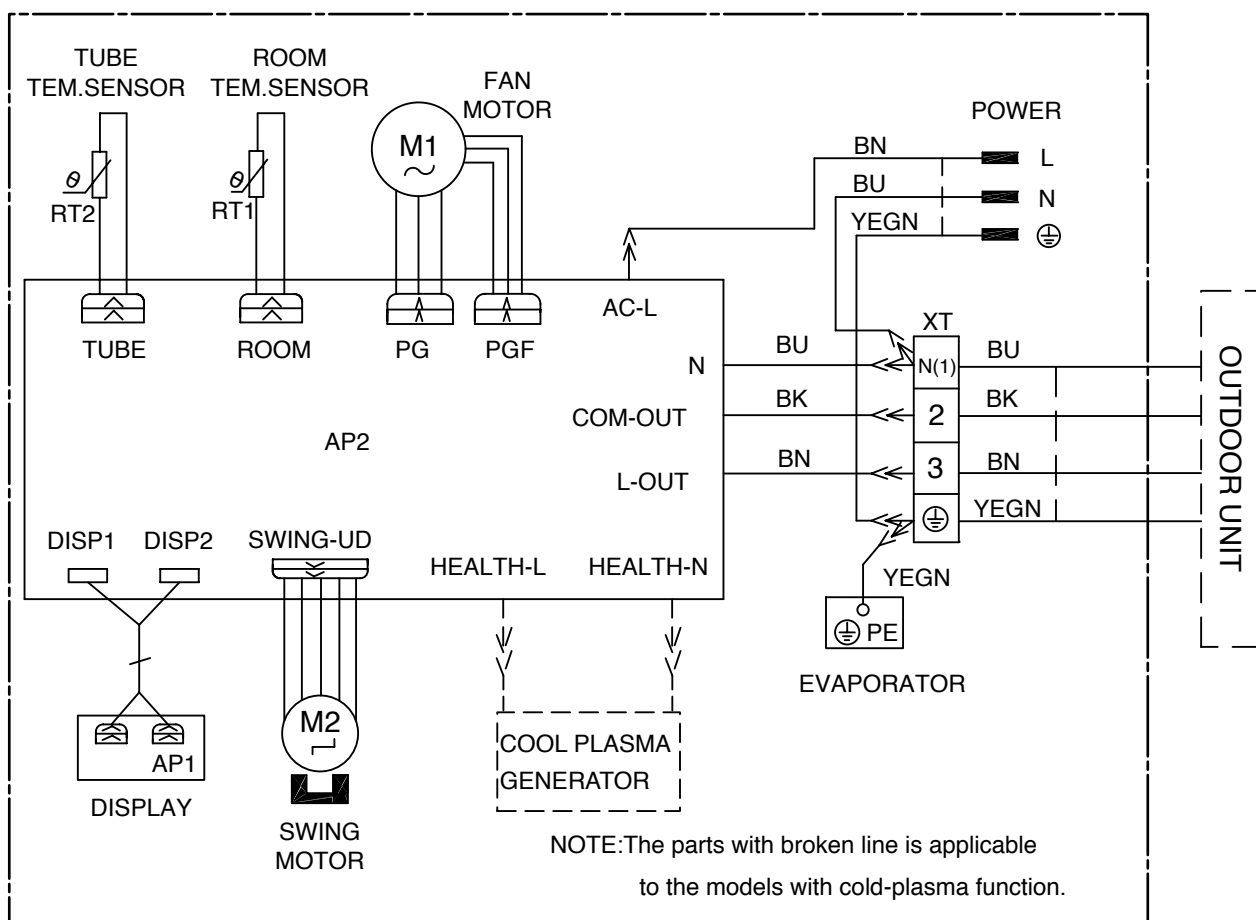

Outdoor Unit **SAP-CRV9AEH**  
**SAP-CRV12AEH**

Symbol	Parts name	Symbol	Color symbol
<b>L1</b>	REACTOR	<b>WH</b>	WHITE
<b>PCB1 to PCB2</b>	PRINTED CIRCUIT BOARD	<b>YE</b>	YELLOW
<b>S10/S11S40/S70/S80/S90</b>	CONNECTOR	<b>RD</b>	RED
<b>SAT</b>	OVERLOAD	<b>BN</b>	BROWN
<b>COMP</b>	COMPRESSOR	<b>BL</b>	BLUE
	PROTECTIVE EARTH	<b>BK</b>	BLACK
		<b>YEGN</b>	YELLOW GREEN

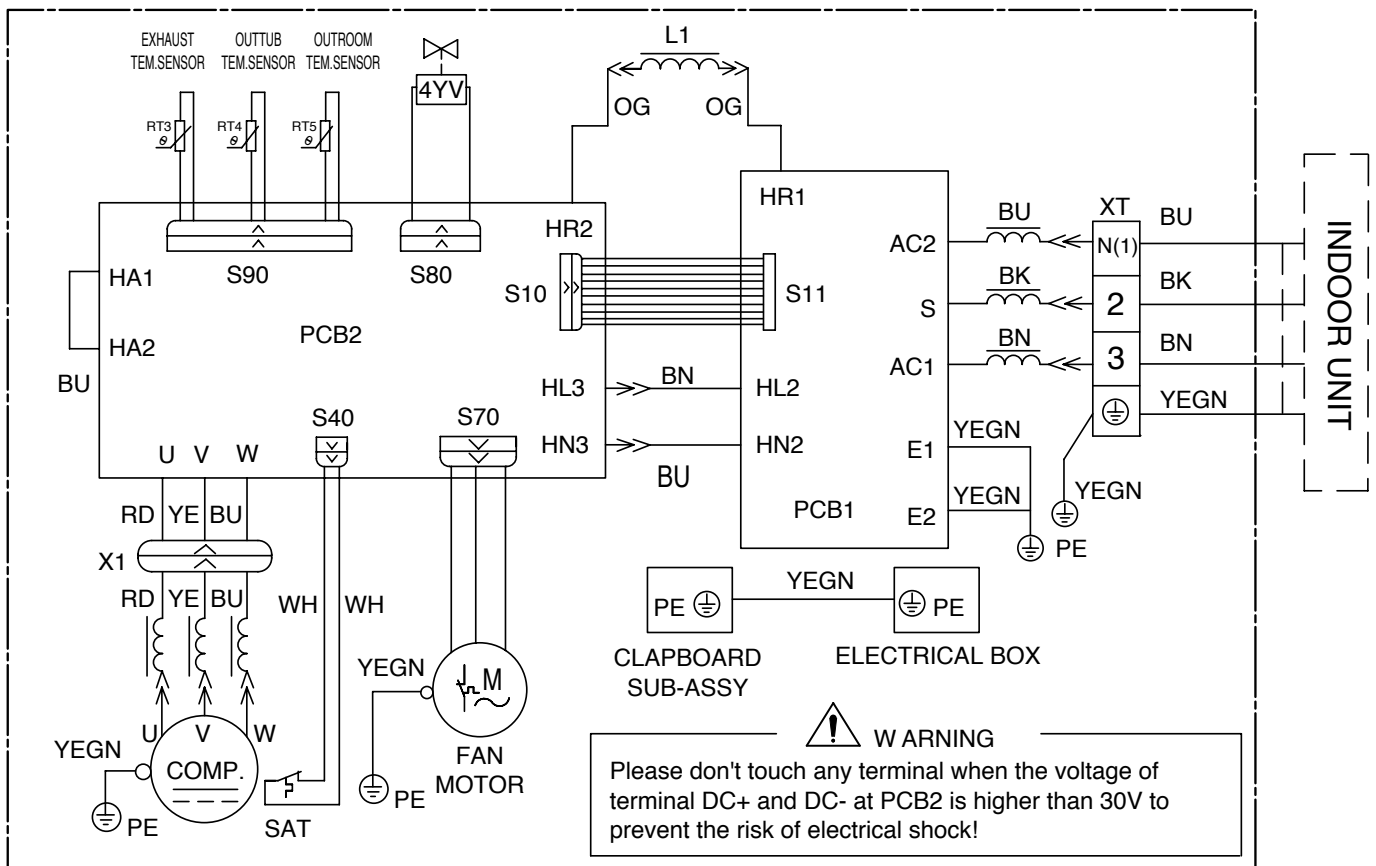

# 7. FUNCTIONS

## 7-1. Main Functions

### 7-1-1. Cooling Mode

- (1) When the air-conditioner is turned on, all the display marks will be shown and only the power LED lights.
- (2) When the air-conditioner is turned on remotely, the power LED goes out while the current setting running mode is displayed.
- (3) During defrosting "H1" is displayed in the display (Dual 8).
- (4) In normal situation, the set temperature is displayed in the display (Dual 8).
- (5) When the signal of displaying indoor temperature or outdoor temperature is received from the controller, the corresponding temperature will be shown in the display (Dual 8).  
It resume displaying set temperature 5 seconds later.

### 7-1-2. Dry Mode

- (1) In this mode, the fan motor runs at low fan speed while works according to setting state.  
The temperature setting range is from 16 to 30 °C.
- (2) When outdoor malfunction or protection stoppage happen, the indoor fan will remain the original running state and the error LED will light.

### 7-1-3. Fan Mode

- (1) In this mode, the indoor fan may run at high, medium, low and automatic speed.  
The compressor, outdoor fan and 4-way valve all stop running.
- (2) In this mode, the temperature setting range is from 16 to 30 °C.

### 7-1-4. Heating Mode

#### (1) Operation Conditions and Heating Process

When the room temperature rises to 1.5 °C or higher than set temperature, the air-conditioner will stops heating. Both outdoor fan and indoor fan will stop later.

When the room temperature falls to 1.5 °C or lower than set temperature, the air-conditioner will starts heating. In that case, indoor fan, outdoor fan and compressor will start running.

The indoor fan works according to the anti-cold air.

In this mode, the temperature setting range is from 16 to 30 °C.

#### (2) Defrosting Control

When the defrosting signal is received, the defrosting mark "H1" will be shown on the indicator of the indoor unit.

### (3) Protection Function

A. When the compressor stops as a result of malfunction, the indoor fan blows residual heat.

B. Anti-cold air function

The rotational speed of indoor fan motor is decided based on the indoor pipe temperature.

When the anti-cold air function is carried out, the indoor fan can run at low speed or stop running.

This function will terminate after the air-conditioner runs for 3 minutes or the pipe temperature reached certain value.

If the indoor pipe temperature is lower than certain value, the running speed of the indoor fan will decrease automatically based on the pipe temperature and ensure that the outlet air is hot.

C. Residual heat blowing function

When the stopping condition for the compressor is reached, the compressor and outdoor fan motor stop running while the upper and lower louver rotate to level L, the indoor fan will stop after running for 60 seconds at setting speed.

### 7-1-5. Auto Changeover Mode

In this mode, the system selects the running mode (cooling, heating and fan) automatically according to the ambient temperature. The display shows the actual running mode and set temperature.

There will be 30 seconds delay for mode conversion.

The protection function is the same as that of other modes.

- When room temperature is 25 °C or more, the cooling mode is selected.
- When room temperature is 22 °C or less, the air-conditioner runs in heating mode.
- When the room temperature is higher than 22 °C and lower than 25 °C, upon initial startup, the air-conditioner will enter auto mode and run in automatic fan mode.

If the other mode changes into auto mode, the previous running mode will remain.

### 7-1-6. Auto Fan Speed Mode

In this mode, the rotational speed of the indoor fan is decided by the different temperature between ambient and set temperature.

In dehumidifying mode, the automatic fan speed is forced to be low.

#### <Indoor Fan Control>

No. of jumper cap	Unit type	Mode	Super-high fan speed	High fan speed	Medium fan speed	Low fan speed
1	9000 BTU	Rotational speed during cooling	1300	1100	900	700
		Rotational speed during heating	1300	1140	980	820
2	12000 BTU	Rotational speed during cooling	1350	1150	950	750
		Rotational speed during heating	1350	1190	1020	850



## 7-1-7. Louver Control

When the air-conditioner is turned on, the motor of upper and lower swing will enable the louver to be open and then close completely (the air outlet is closed).

In heating mode, if the swing function is not set, the upper and lower louver will rotate to maximum in clockwise direction. Then, it will rotate to place "D".

Under other state, the upper and lower louver will rotate to place "L".

If the swing function is set when starting the air-conditioner the louver will swing between place "L" and "D".

There are 7 states for the louver: in place "L", "A", "B", "C", "D", and swing between "L" and "D", stop in any place between "L" and "D".

When the air-conditioner is turned off, the louver will stay in place "O".

The swing is available only when the swing function is set and the indoor fan is running.

**NOTE** When place "L" to "B", place "A" to "C", and place "B" and "D" is set, the louver will swing between place "L" to "D".

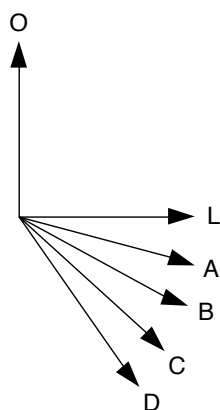

## 7-1-8. Sleep Function

**NOTE** It is applicable to cooling, dehumidifying and heating mode.

A. In the case that the sleep function is set in the cooling or dry mode, 1 hour later, set temperature rises by 1 °C, and 3 hours later, it rises by 1 °C more. The operation of the air-conditioner is continued with the set temperature as (T + 2) °C.

### ● Cooling or Dry Operation

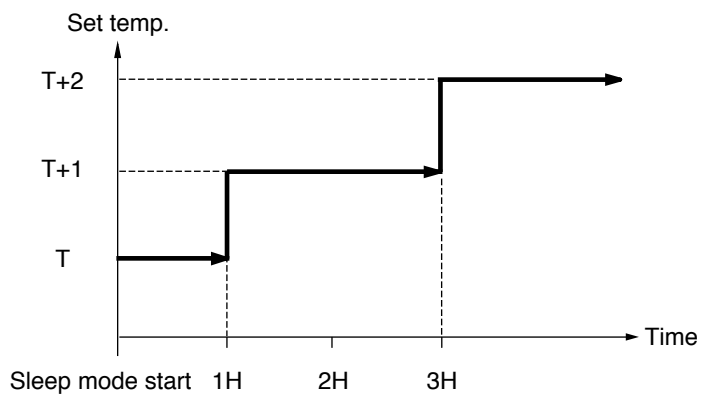

B. In the case that the sleep function is set in the heating mode of the air-conditioner, 1 hour later, the set temperature drops by 1 °C and 3 hours later, it drops by 1 °C more. The operation of the air-conditioner is continued with the set temperature as (T - 2) °C.

### ● Heating Operation

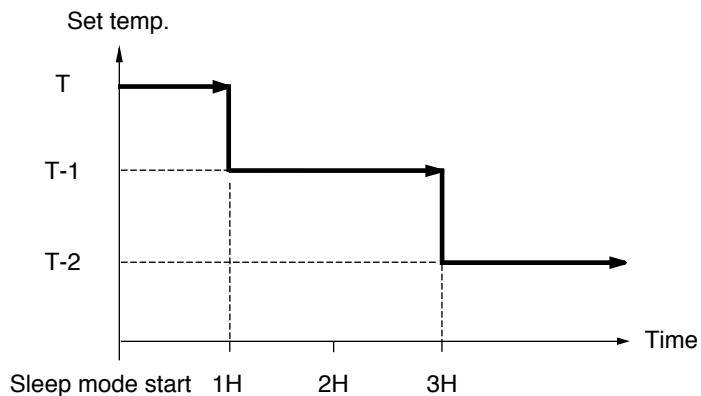

## 7-1-9. Timer Function

The main board has general timer function and clock function.

The timer function can be selected by remote controller with different function.

### A. General Timer

Start and stop time can be set. The accuracy is minute.

e.g. Timer on for 1 hour; timer off for 1.5 hours

Timer ON : After setting timer on, the air-conditioner will run at setting time according to the original setting mode. The timing interval is 0.5 hour, and the setting range is 0.5 to 24 hours.

Timer OFF : The timer off function can be set when the air-conditioner is on.

When the setting for timer off is reached, the air-conditioner will stop.

the timing interval is 0.5 hour, and the setting range is 0.5 to 24 hours.

### B. Clock Timer

Start and stop time can be set. The accuracy is minute.

e.g. Timer on at 8:00 a.m.; timer off at 17:30 p.m.

Timer ON : If the timer on function is set when the air-conditioner is on, the air-conditioner will go running.

If the timer on function is set when the air-conditioner is off, the air-conditioner will start running in the previously set mode when the setting time is reached.

Timer OFF : The timer off function is set when the air-conditioner is off, the air-conditioner will keep off even though the setting time is reached.

If the timer off function is set when the air-conditioner is on, the air-conditioner will stop running when the setting time is reached.

#### **NOTE**

#### 1. Setting time change

When the air-conditioner is under timer state, start or stop of the air-conditioner can be set by remote controller ON/OFF button and timer can be reset.

The air-conditioner runs according to the latest setting state.

#### 2. When both the timer on and off are set, the air-conditioner runs according to the current setting state. When the setting time is reached, the air-conditioner will start and stop running. In that case, the air-conditioner will run according to the previously setting mode when the setting time for timer on is reached .

The air-conditioner will stop running while the setting time for timer off is reached.

If the setting time for timer on and off is the same, the air-conditioner will stop running no matter what the current state is.

## 7-1-10. Auto-restart Function

**NOTE** Memory Contents : mode, up and down swing, light, set temperature, setting fan speed, general timer (not clock), Fahrenheit / Celsius

After de-energized, the air-conditioner can run according to the memory contents if it is energized again.

If the timer function is not set in the last remote control, the air-conditioner will run according to the last remote control.

If the timer function is set in the last control before it is de-energized, the air-conditioner will memorize the last timer setting. The setting is recalculated since the energization of the air-conditioner.

If the timer function is set in the last control and the setting is reached before the air-conditioner is de-energized, the air-conditioner will run according to the previous running mode after it is energized again.

But the timer function will terminate. The clock will not be memorized.

## 7-1-11. Turbo Function

In cooling and heating mode (not available in auto, dehumidify and fan mode), press the Turbo button, the fan speed displayed super high speed in the remote controller and the indoor fan rotates at super high speed.

## 7-2. Control Specifications

### 7-2-1. Frequency Control

#### (1) Frequency Initial Setting

##### <Outline>

When starting compressor, or when conditions are varied due to the change of the room, the frequency must be initialized according to the  $\Delta D$  value of the indoor unit and the Q value of the indoor unit.

$\Delta D$  signal : Indoor frequency command

Q value : Indoor unit output determined from indoor unit volume, air flow rate and the other factors.

#### (2) PI Control (Determine Frequency Up/Down by $\Delta D$ signal)

##### (2-1) P control

Calculate  $\Delta D$  value in each sampling time (20 seconds), and adjust the frequency according to its difference from the frequency previously calculated.

##### (2-2) I control

If the operation frequency is not change more than a certain fixed time, adjust the frequency up and down according to the  $\Delta D$  value, obtaining the fixed  $\Delta D$  value.

When the  $\Delta D$  value is small, lower the frequency.

When the  $\Delta D$  value is large, increase the frequency.

##### (2-3) Frequency management when other controls are functioning

- When frequency is drooping, frequency management is carried.
- For limiting lower limit, frequency management is carried out only when frequency rises.

##### (2-4) Upper and lower limit of frequency by PI control

The frequency upper and lower limits are set depending on indoor unit.

When low noise commands come from the indoor unit or when outdoor unit low noise or quiet commands come from indoor unit, the upper limit frequency must be lowered than the usual setting.

### 7-2-2. 3-minutes Standby

Prohibit to turn ON the compressor for 3 minutes after turning it off (except when defrosting).

### 7-2-3. Compressor Protection Function

When turning the compressor from OFF to ON, the upper limit of frequency must be set as follows.

(The function must not be used when defrosting).

FCG 3	88
FCG 2	64
FCG 1	48
TCG1	240
TCG2	360
TCG3	180

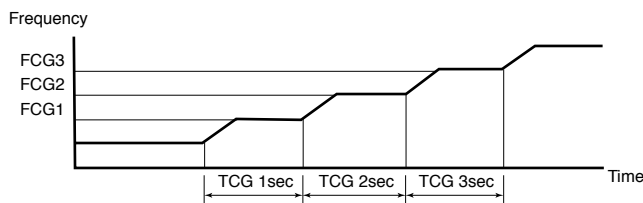

## 7-2-4. Discharge Pipe Control

### <Outline>

The discharge pipe temperature is used as the compressor's internal temperature.

If the discharge pipe temperature rises above a certain level, the operating frequency upper limit is set to keep this temperature from going up further.

### <Detail>

#### • Divide the Zone

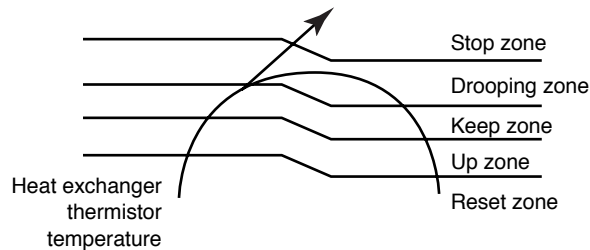

#### • Management within the Zones

Zone	Control Contents
Stop zone	When the temperature reaches the stop zone, stop the compressor and correct abnormality
Drooping zone	Start the timer, and the frequency will be drooping.
Keep zone	Keep the upper limit of frequency.
Return / Reset zone	Cancel the upper limit of frequency.

## 7-2-5. Input Current Control

### <Outline>

Detect an input current by the CT during the compressor is running, and set the frequency upper limit from such input current.

In case of heat pump model, this control is the upper limit control function of the frequency which takes priority of the lower limit of 4-way valve activating compensation.

### <Detail>

The frequency control will be made within the following zones.

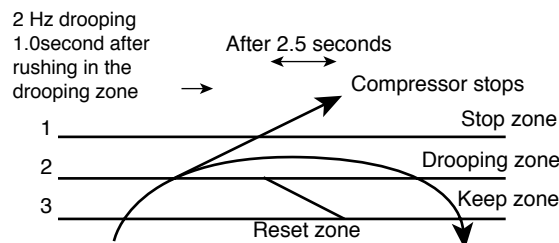

When a "stop current" continues for 2.5 seconds after rushing on the stop zone, the compressor operation stops. If "drooping current" is continues for 1.0 second after rushing on the drooping zone, the frequency will be 2Hz drooping.

Repeating the above drooping continues until the current rushes on the drooping zone without change.

In the keeping zone, the frequency limit will remain.

In the return and reset zone, the frequency limit will be cancelled,

• **Limitation of current drooping and stop value according to the outdoor air temperature**

- (1) In case the operation mode is cooling
  - The current droops when outdoor air temperature becomes higher than a certain level (model by model).
- (2) In case the operation mode is heating
  - The current droops when outdoor air temperature becomes higher than a certain level (model by model).

**7-2-6. Freeze-up Protection Control**

**<Outline>**

During cooling operation, the signals being sent from the indoor unit allow the operating frequency limitation and then prevent freezing of the indoor heat exchanger. (The signal from the indoor unit must be divided into the zones as the followings).

**<Detail>**

• **Conditions for Start Controlling**

Judge the controlling start with the indoor heat exchanger temperature after 2 seconds from operation start.

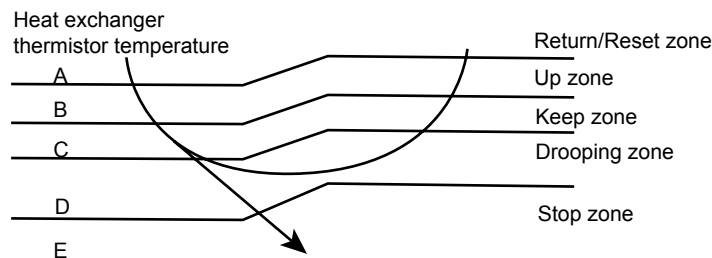

**7-2-7. Heating Peak-Cut Control**

**<Outline>**

During heating operation, the signals being sent from the indoor unit allow the operating frequency limitation and prevent abnormal high pressure. (The signal from the indoor unit must be divided as follows).

**<Detail>**

• **Conditions for Start Controlling**

Judge the controlling start with the indoor heat exchanger temperature after 2 seconds from operation start

• **Control in Each Zone**

The heat exchanger intermediate temperature of indoor unit controls the following.

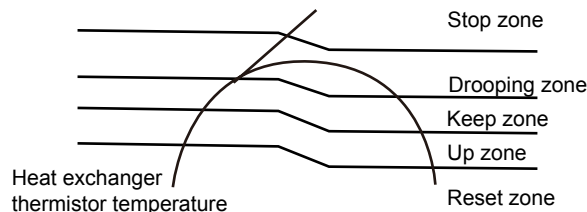

## 7-2-8. Defrost Control

### <Outline>

Defrosting carried out by the cooling cycle (reverse cycle). The defrosting time or outdoor heat exchanger temperature must be more than its fixed value when finishing.

### <Detail>

#### • Conditions for Starting Defrost

The starting condition must be made with the outdoor air temperature and heat exchanger temperature. Under the conditions that the system is in heating operation, 6 minutes after the compressor is started and more than 44 minutes of accumulated time pass since the start of the operation or ending the defrosting.

#### • Conditions for Canceling Defrost

The judgment must be made with heat exchanger temperature. ( 4 °C to 22 °C)

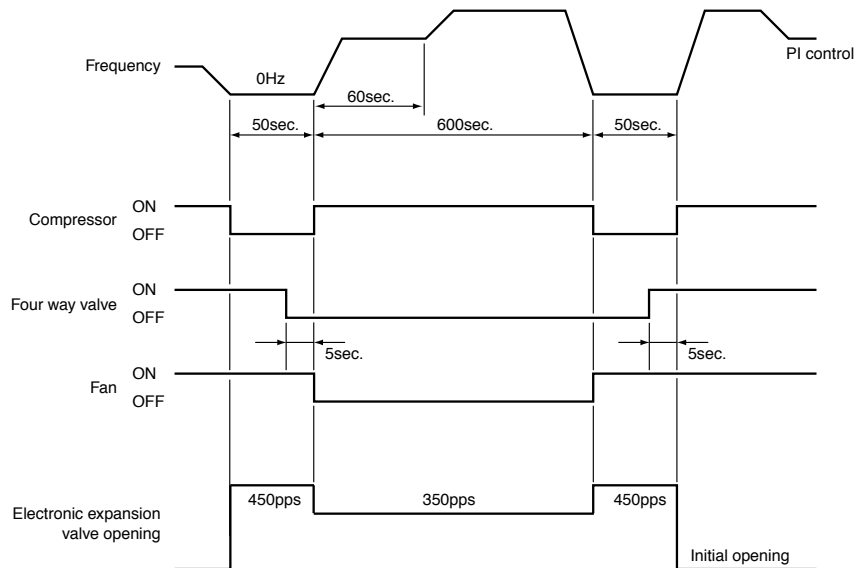

## 7-2-9. Fan Control

### <Outline>

Fan control is carried out according to the following priority.

- (1) Fan ON control for electric component cooling fan
- (2) Fan control when defrosting
- (3) Fan OFF delay when stopped
- (4) ON/OFF control in cooling operation
- (5) Tap control when drooping function is working.
- (6) Fan control in forced operation
- (7) Fan control in indoor / outdoor unit silent operation
- (8) Fan control in powerful mode
- (9) Fan control in normal operation

### <Detail>

Fan OFF Control when Compressor is Stopped.

- Fan OFF delay for 60 seconds must be made when the compressor is stopped.

Tap Control in indoor / outdoor unit silent operation

- (1) Cooling Operation

When the outdoor air temperature is lower than 37 °C, the fan tap must be set to L.

- (2) Heating Operation

When the outdoor air temperature is higher than 4 °C, the fan tap must be turned to L.





## 7-2-10. Temperature Sensor Malfunction Detection

- (1) Indoor Temperature Sensor  
Detect malfunctions of temperature sensor any time.
- (2) Indoor Pipe Temperature Sensor  
In defrosting period, the temperature sensor malfunction will not be detected.  
5 minutes after finishing defrosting, the system begins to detect the temperature sensor malfunction.  
In other times, the temperature sensor malfunction will be detected.
- (3) Protection of Temperature Sensor
  - (3-1) When short-circuit occurs to the temperature sensor for 30 seconds  
The temperature sensor overheats. In this case, the complete unit will stop for protection.  
At the same time, the temperature protection and temperature sensor malfunction will be shown.
  - (3-2) When break-circuit occurs to the temperature sensor for 30 seconds  
The unit will stop and the temperature sensor malfunction will be displayed.

## 8. TROUBLESHOOTING

### 8-1. Precautions before Performing Inspection or Repair

 <b>Warning</b>	<ul style="list-style-type: none"><li>● To avoid electrical shock hazard, be sure to disconnect power before attempting to disassemble the unit.</li><li>● When a footstool, etc. is used for disassembling the indoor unit, be careful not to fall down. If you fall down, you might be injured seriously.</li></ul>	
--	---	---

Be caution during installation and maintenance. Do operation following the regulations to avoid electric shock and casualty or even death due to drop from high attitude.

- Static maintenance is the maintenance during de-energization of the air conditioner.  
For static maintenance, make sure that the unit is de-energized and the power plug is disconnected.
- Dynamic maintenance is the maintenance during energization of the unit.  
Before dynamic maintenance, check the electricity and ensure that there is ground wire on the site.  
Check if there is electricity on the housing and connection copper pipe of the air conditioner with the voltage tester.  
Take sufficient care to avoid directly touching any of the circuit parts without first turning off the power.  
After ensure insulation place and safety, the maintenance can be performed.

At times such as when the circuit board is to be replaced, place the circuit board assembly in a vertical position. Normally, diagnose troubles according to the trouble diagnosis procedure as described below. Refer to the check points in servicing written on the wiring diagrams to the attached on the indoor/outdoor units.

#### <Precautions when inspecting the control section of the outdoor unit>

A large-capacity electrolytic capacitor is used in the outdoor unit controller (inverter). Therefore, if the power supply is turned off, charge (charging voltage DC280V to 380V) remains and discharging takes a lot of time. After turning off the power source, if touching the charging section before discharging, an electrical shock may be caused.  
The outdoor unit can be open after the unit is de-energized for 20 minutes.

#### <Troubleshooting procedure>

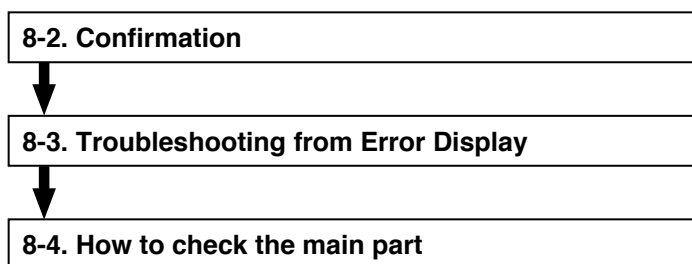

### 8-2. Confirmation

- (1) Confirmation of Power Supply  
Confirm that the power breaker operates (ON) normally.
- (2) Confirmation of Power Voltage  
Confirm that the power voltage is AC 220V +/- 10%, AC 230V +/- 10% or AC 240V +/- 10%.  
If power voltage is not in this range, the unit may not operate normally.

## 8-3. Troubleshooting from Error Display

**NOTE** 4 minutes after protection stop of compressor, the malfunction is shown in error code.  
In other situation, the malfunction will be displayed by press the light button for 6 times within 4 seconds.

Code	Malfunction	Error Display		Repair Method
		Dual 8 Display	LED	
1	Storage slug	EE	Heating LED-pause 3 seconds and blink 15 times	Replace indoor main board.
2	Indoor PCB malfunction	EE	Heating LED-pause 3 seconds and blink 15 times	Replace indoor main board.
3	Anti-freezing protection	E2	Running LED-pause 3 seconds and blink 2 times	Outdoor ambient temperature is too low.
4	Overload of system	H4	Heating LED-pause 3 seconds and blink 4 times	System is abnormal, check if the evaporator and condenser is dirty and blocked.
5	No motor of indoor unit feedback	H6	Running LED-pause 3 seconds and blink 11 times	Is electromotor mounted normally ?
6	Indoor pipe temperature sensor malfunction	F2	Cooling LED-pause 3 seconds and blink 2 times	Is it loose ? Measure the resistance value with universal meter.
7	Internal ambient temperature sensor malfunction	F1	Cooling LED-pause 3 seconds and blink 1 time	Is it loose ? Measure the resistance value with universal meter.
8	Zero passage abnormal	UF	Heating and cooling LED blink 7 times at the same time	Replace indoor main board.
9	Overload of compressor	H3	Heating LED-pause 3 seconds and blink 3 times	Inspect connection state of the overload wire.
10	Startup failure	LC	Heating LED-pause 3 seconds and blink 11 times	Check if the resistance of compressor and resistance to ground is normal. If the compressor is normal, the outdoor main board may be wrong.
11	No motor of outdoor unit feedback	UH	Heating and cooling LED blink 8 times at the same time	This malfunction may happen when outdoor DC electromotor is used.
12	Over current protection	E5	Running LED-pause 3 seconds and blink 5 times	Is electric network variable ?
13	4-way valve conversion abnormal	U7	Cooling LED-pause 3 seconds and blink 20 times	Replace 4-way valve.
14	Phase current detection malfunction of compressor	U1	Heating LED-pause 3 seconds and blink 13 times	Replace outdoor main board.
15	Sync failure	H7	Heating LED-pause 3 seconds and blink 7 times	Check if the resistance of compressor and resistance to ground is normal. If the compressor is normal, the outdoor main board may be wrong.

Code	Malfunction	Error Display		Repair Method
		Dual 8 Display	LED	
16	Current detection malfunction of complete unit	U5	Cooling LED-pause 3 seconds and blink 13 times	Replace outdoor main board.
17	Outdoor ambient temperature sensor malfunction	F3	Cooling LED-pause 3 seconds and blink 3 times	Is it loose ? Measure the resistance value with universal meter.
18	Discharge protection of compressor	F4	Running LED-pause 3 seconds and blink 4 times	Is it loose ? Measure the resistance value with universal meter.
19	Break-circuit and short-circuit of outdoor discharge temperature sensor	F5	Cooling LED-pause 3 seconds and blink 5 times	Is it loose ? Measure the resistance value with universal meter.
20	Break-circuit and short-circuit of outdoor condenser temperature sensor	F4	Cooling LED-pause 3 seconds and blink 18 times	Is it loose ? Measure the resistance value with universal meter.
21	Overheat of carbon fin	P8	Heating LED-pause 3 seconds and blink 19 times	Is outdoor ambient temperature is too high ? Is radiator mounted correctly ?
22	DC over current	UU	Heating and cooling LED blink 11 times at the same time	
23	Temperature sensor malfunction of carbon fin	P7	Heating LED-pause 3 seconds and blink 18 times	Replace outdoor main board.
24	Lack of Freon or block protection	F0	Cooling LED-pause 3 seconds and blink 10 times	
25	DC input voltage is too high	PH	Cooling LED-pause 3 seconds and blink 11 times	Is voltage of AC power supply normal ?
26	DC input voltage is too low	PL	Heating LED-pause 3 seconds and blink 21 times	Is voltage of AC power supply normal ?
27	Communication malfunction	E6	Running LED-pause 3 seconds and blink 6 times	Is Outdoor connecting wire reliably connected ?
28	Setting error. Indoor and outdoor unit abnormal	UA	Heating and cooling LED blink 12 times at the same time	Outdoor unit is not matched with indoor unit.

## 8-4. How to check the main part

### 8-4-1. Malfunction of power supply from indoor unit to outdoor unit

#### < Main Inspection Points >

Inspect the power supply plug seat with AC voltage gauge to check if the voltage between L and N is within 200VAC to 240VAC.

Check with AC voltage gauge if the voltage between N1 and 3 of indoor wiring block is within 200VAC to 240VAC.

Check with AC voltage gauge if the voltage between L and N outdoor wiring block is within 200VAC to 240VAC.

#### < Malfunction Diagnosis Process >

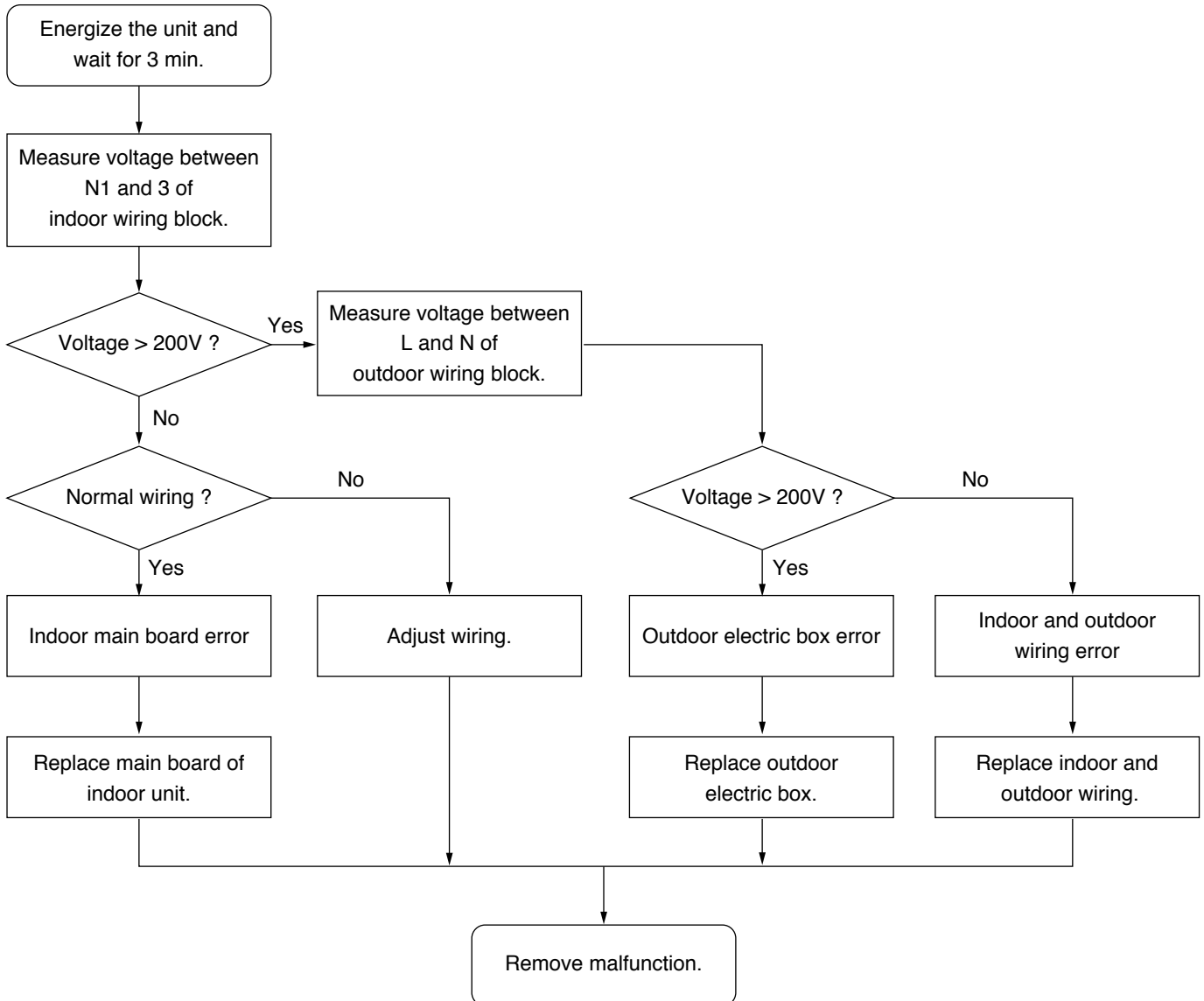

## 8-4-2. Indoor fan does not rotate.

### < Main Detection Points >

- Is the control panel reliably connected with the electromotor ?  
Is it loose ? Is the connecting sequence correct ?
- Is the input voltage within the normal range (measure the voltage between L and N of the wiring block XT with AC voltage gauge.) ?

### < Malfunction Diagnosis Process >

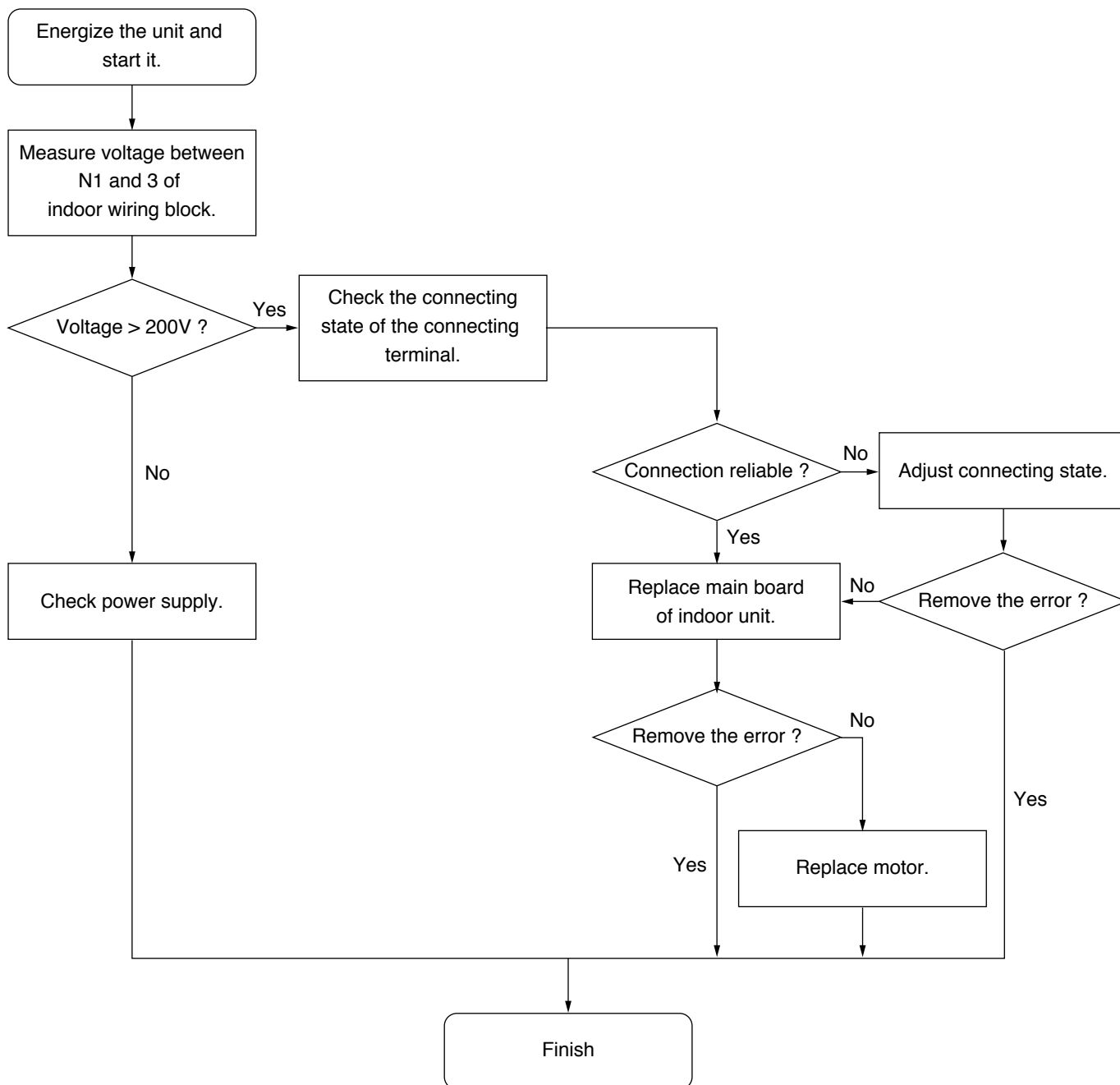

### 8-4-3. Temperature sensor malfunction

#### < Main Detection Points >

- Is outdoor ambient temperature within the normal range ?
- Is indoor and outdoor fan running normally ?
- Is the radiating environment inside and outside the unit good enough ?

#### < Malfunction Diagnosis Process >

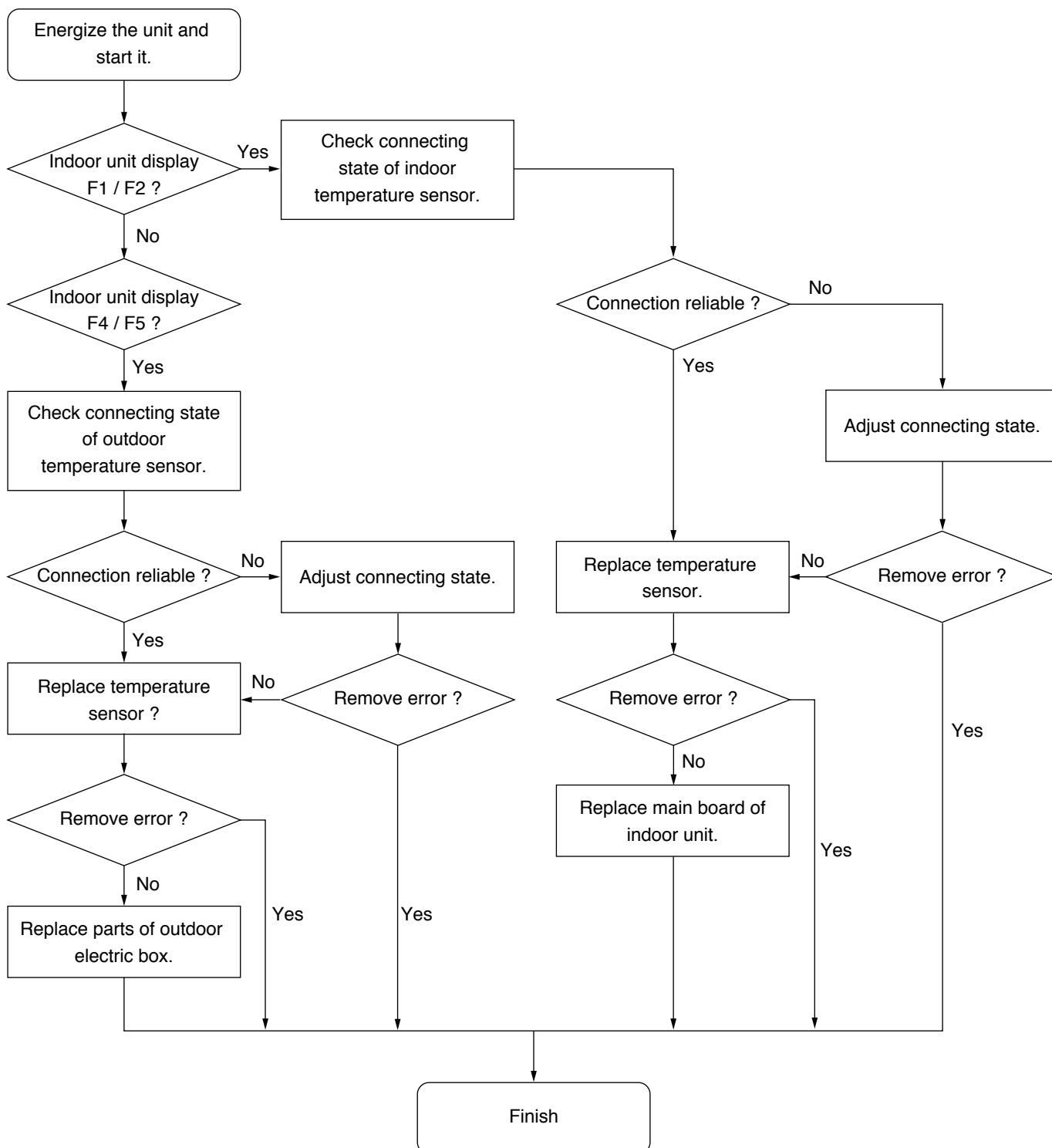

## 8-4-4. Malfunction diagnosis of start-up failure

### < Main Detection Points >

- Is wiring of compressor correct ?
- Is the stop time of compressor enough ?
- Is compressor damaged ?

### < Malfunction Diagnosis Process >

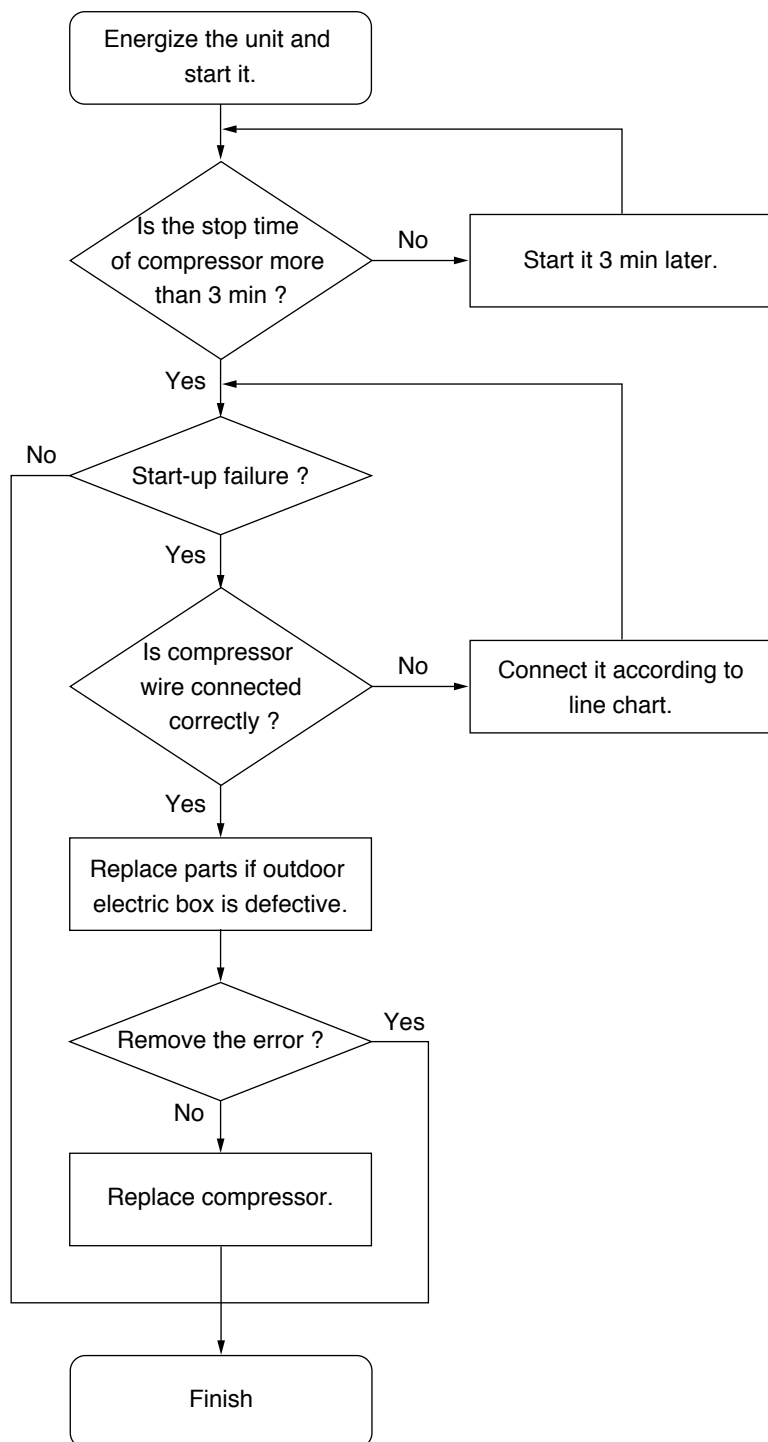



## 8-4-5. Diagnosis of losing synchronism for compressor

### < Main Detection Points >

- Is pressure of the system too high ?
- Is voltage too low ?

### < Malfunction Diagnosis Process >

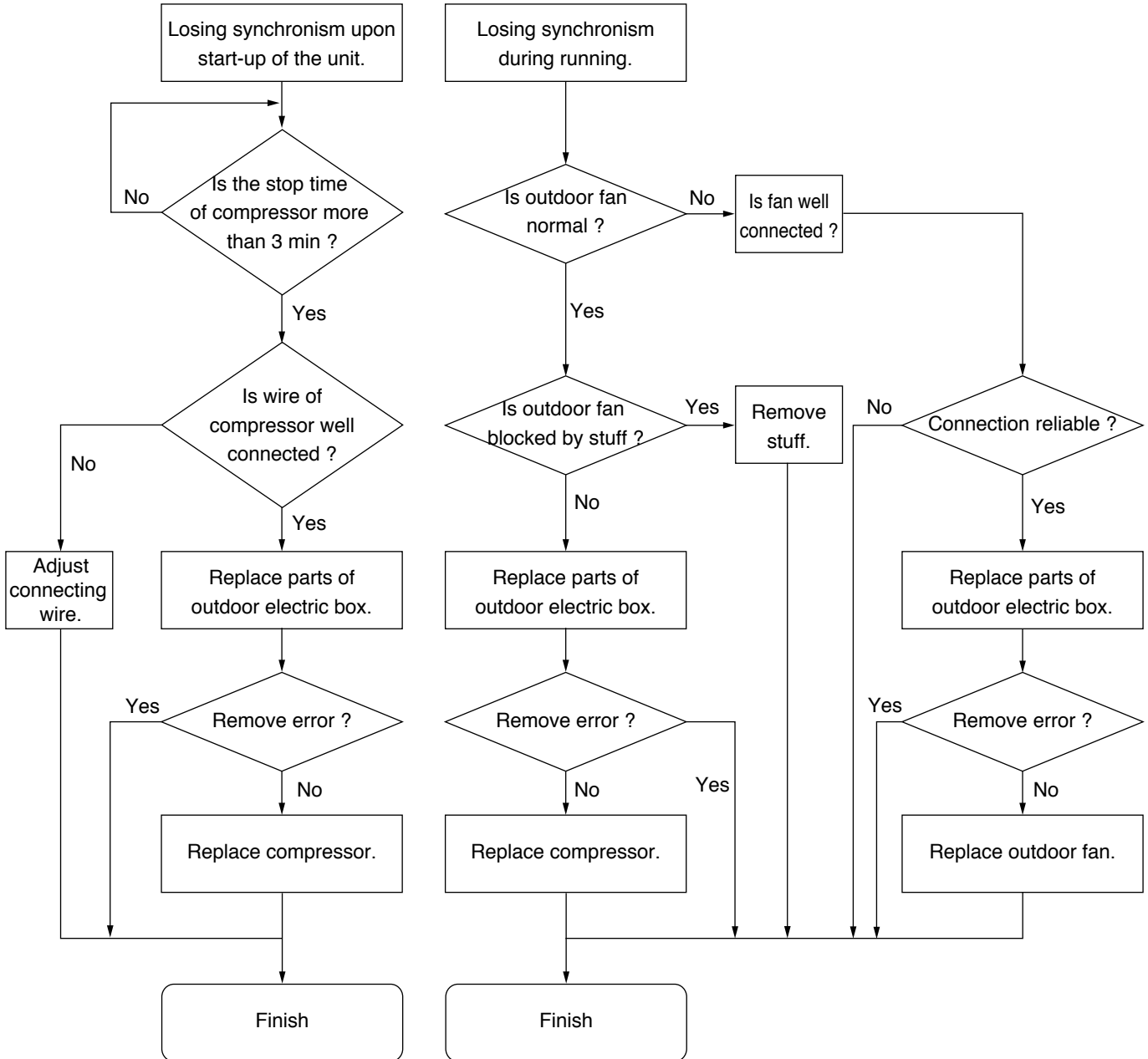

## 8-4-6. Diagnosis of overload and discharge malfunction

### < Main Detection Points >

- Is electric expansion valve well connected ? Is it damaged ?
- Is refrigerant leaked ?
- Is overload wire connection normal ?

### < Malfunction Diagnosis Process >

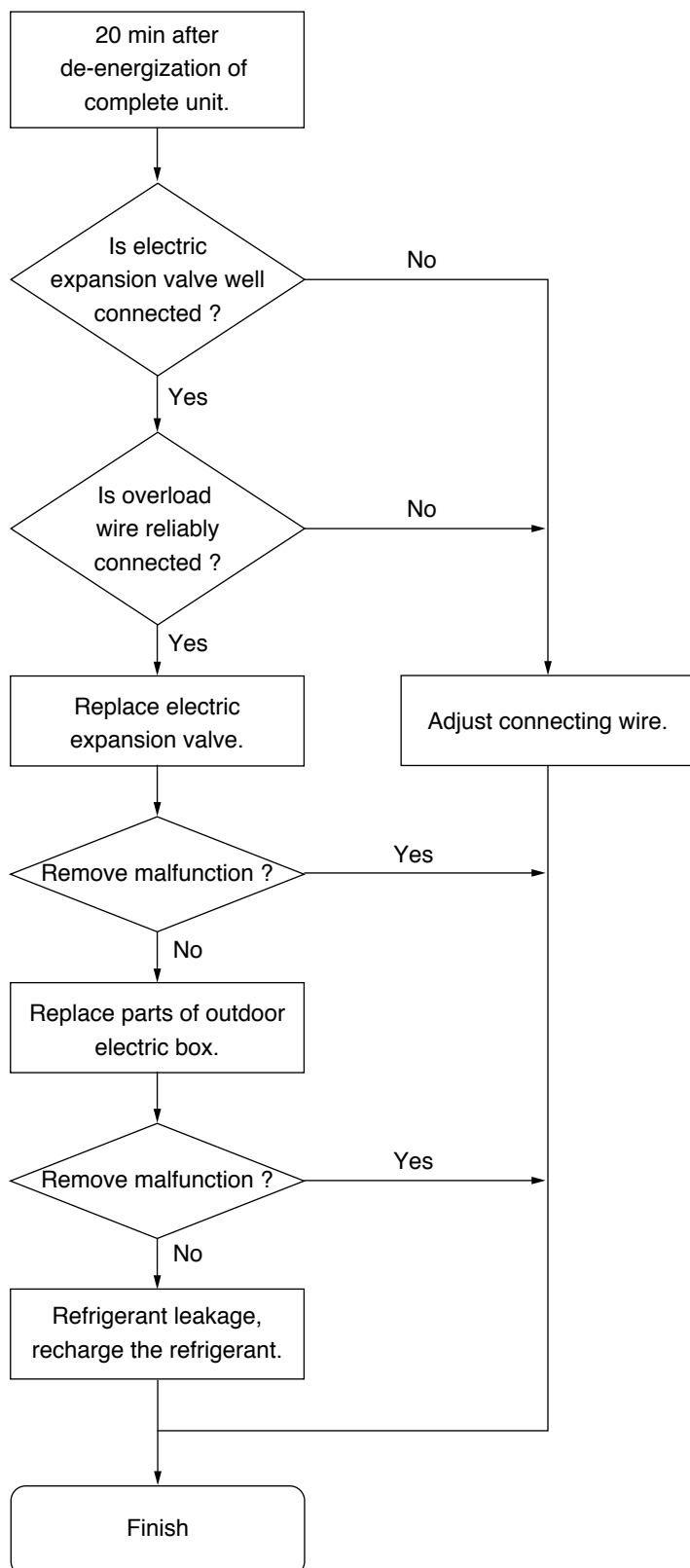

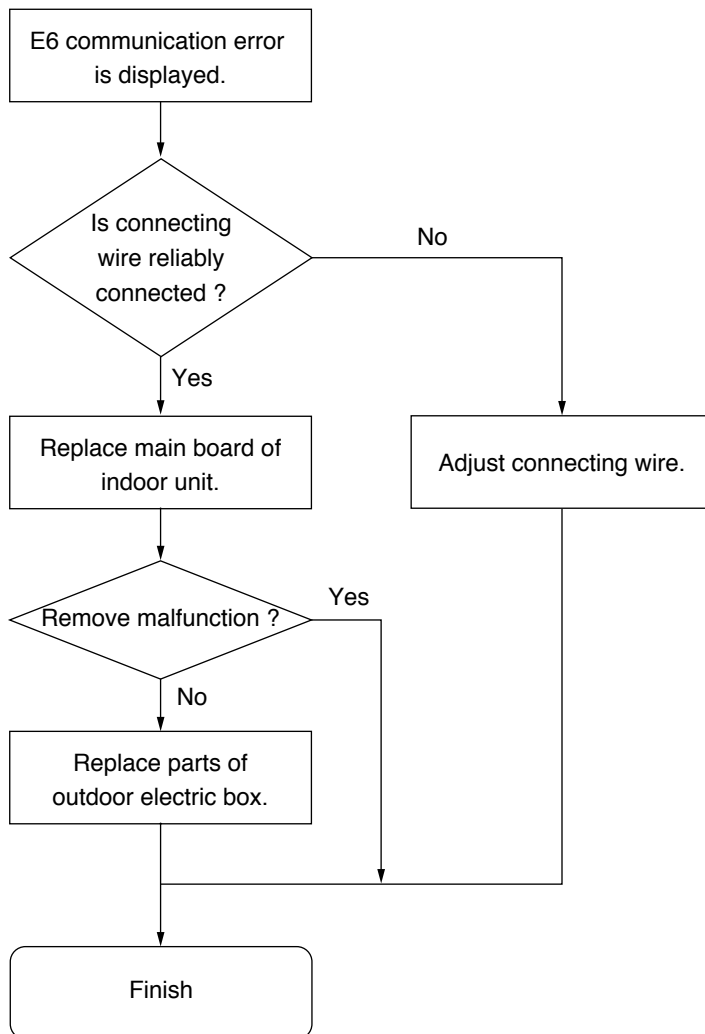

## 8-4-7. Process of communication circuit detection

### < Malfunction Diagnosis Process >



## 9. DISASSEMBLY PROCEDURE

### 9-1. Disassembly Procedure of Indoor Unit

 <b>Warning</b>	To avoid electrical shock hazard, be sure to disconnect all power and wait 10 minutes or more before attempting to disassemble the unit.	
--	--	---

#### 9-1-1. Remove the air filters

- (1) Pull protrusions on left and right sides of panel with fingers and open front grille all the way. (Fig.1)
- (2) Lift center section of air filter and disengage hooks. (Fig.2)  
**NOTE** 1. Left and right filters are interchangeable.  
2. To re- install, insert air filter along the guide.
- (3) Remove air filter by pulling forward. (Fig.3)

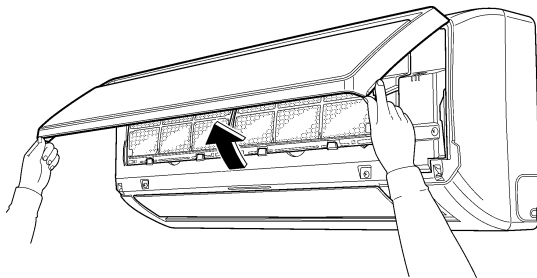

Fig. 1

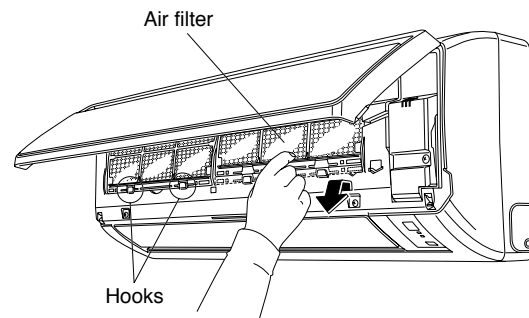

Fig. 2

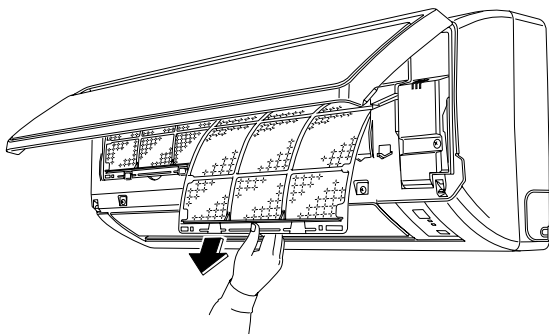

Fig. 3

## 9-1-2. Opening and shutting front panel

- (1) Pull down horizontal blade by pulling forward. (Fig.4)

**NOTE** Support the front panel by one hand, while remove the rotation axis at the upper center by the other hand. And pull out the front panel forward to remove.

- (2) Remove horizontal blade by pulling forward. (Fig.5)

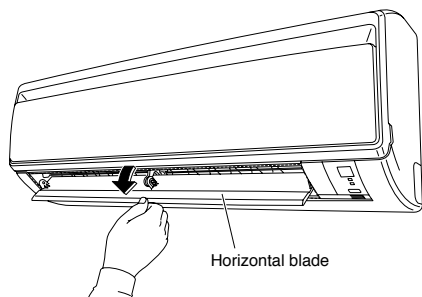

Fig. 4

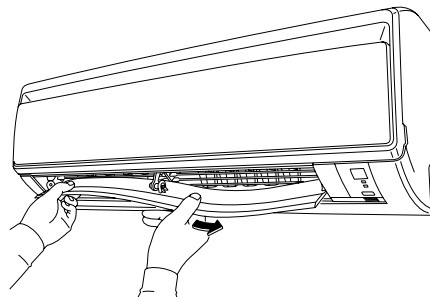

Fig. 5

- (3) Hook a finger onto the projection part provided on the both sides of the unit's panel and open up the panel to the position higher than it will stop. (Fig.6)

**NOTE** 1. Left and right filters are interchangeable.  
2. To re-install, insert air filter along the guide.

- (4) Remove the front panel from the unit. (Fig.7)

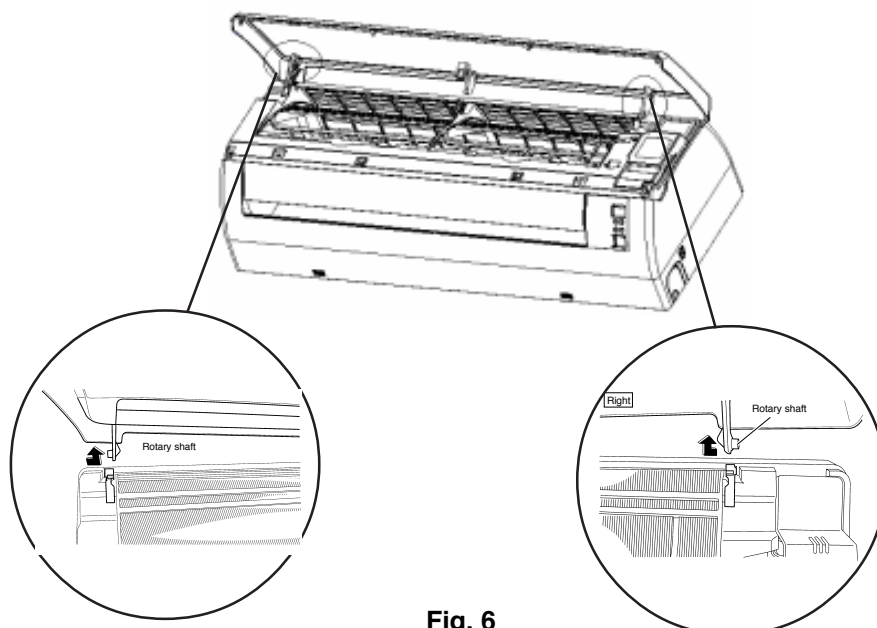

Fig. 6

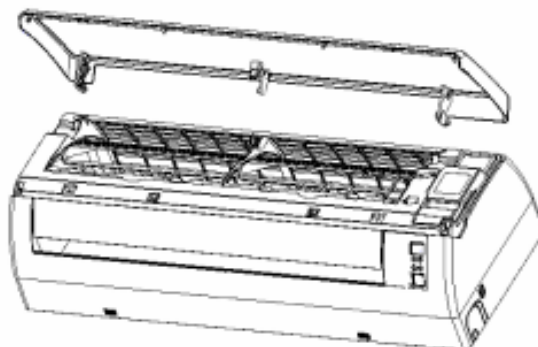

Fig. 7

### 9-1-3. Opening and closing of service cover

- (1) Remove a service cover mounting screw.  
Lift up the service cover. (Fig.8 and Fig.9)

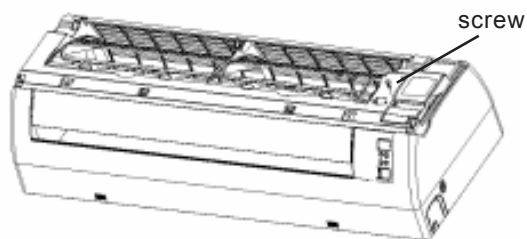

Fig. 8

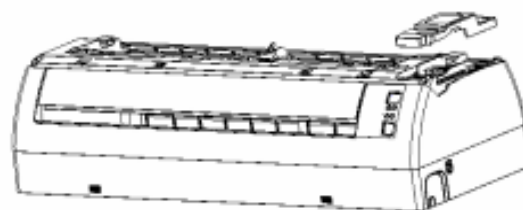

Fig. 9

### 9-1-4. Removing front grille assembly

- (1) Remove the 3 screws, in the right and the left, which fix the main body with the front grille. (Fig.10)

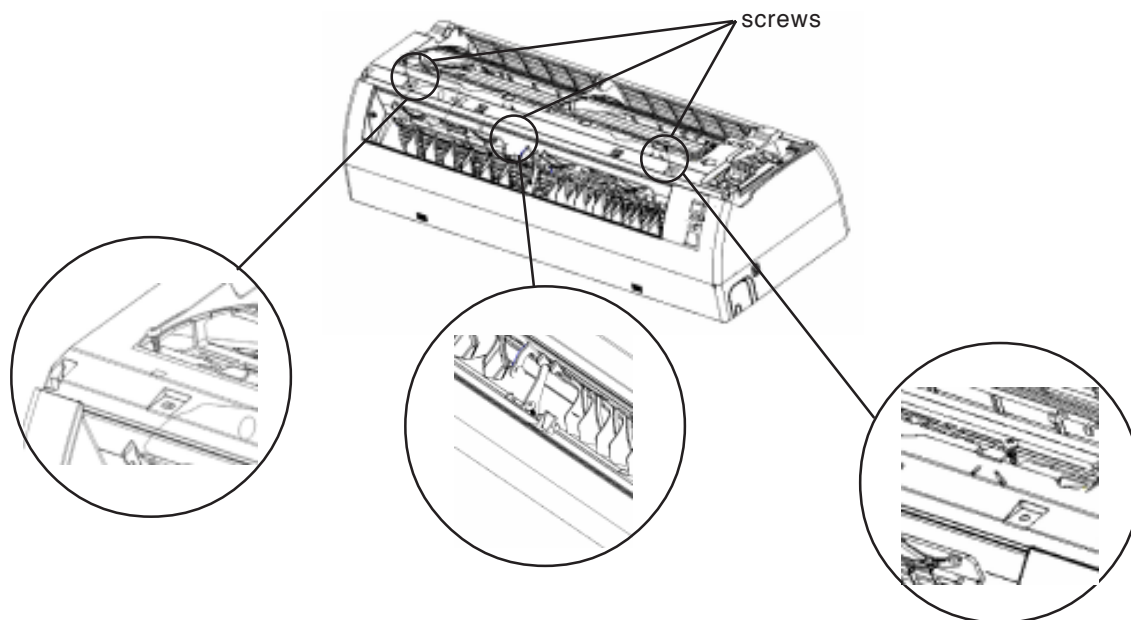

Fig. 10

- (2) Disengage the 3 hooks on the upper part. (Fig.11)  
 In case that the hooks are not pressed from above, remove the front panel and then remove the grille while pushing the hook through a clearance between the front grille and the heat exchanger.  
**NOTE** Disengage the hooks by pressing knobs with a screwdriver.

- (3) The front grille can be removed o pull out the upper part forward and lift up the lower part. (Fig.12)

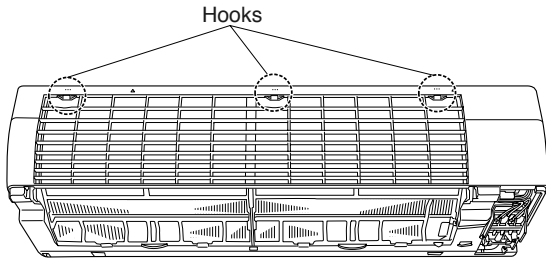

Fig. 11

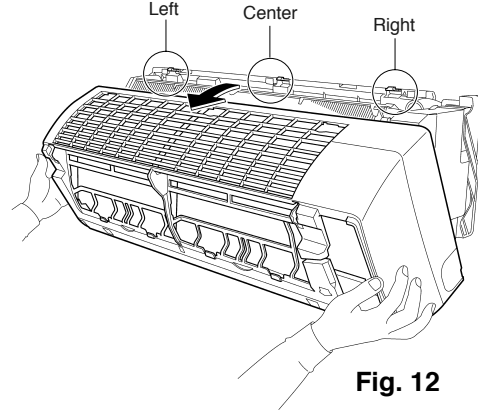

Fig. 12

### 9-1-5. Removing the vertical blade

- (1) Unfasten the hooks at the upper 2 positions. (Fig.13 and Fig.14)

- NOTE** 1. A set of vertical blade has 6 fins as on assy. (It is impossible to replace only one fin.)  
 2. The set of vertical blades is not marked for difference between right and left.

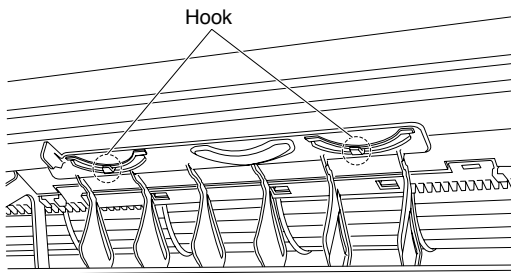

Fig. 13

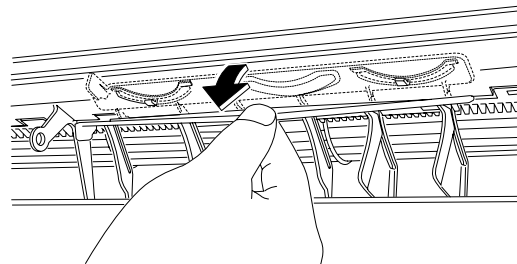

Fig. 14

- (2) Unfasten the 3 hooks at the shaft mounting part by pressing them with a flat screwdriver. (Fig.15)

- NOTE** Repeat the same procedure to remove the vertical blade on the other side.

- (3) Remove the vertical blade. (Fig.16)

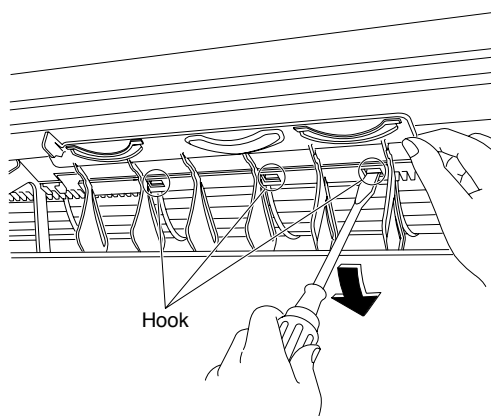

Fig. 15

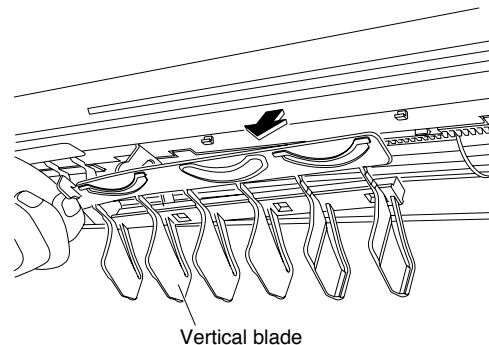

Fig. 16

## 9-1-6. Removing the electrical box

- (1) Disconnect the cable clamp. (Fig.17)

**NOTE** Pay attention to the direction of the retainer of the thermistor so that the retainer will not touch the harness.

- (2) Disconnect the connection wires. (Fig.18)

**NOTE** Take care not to lose the clip of thermistor. (Fig.19)

- (3) Remove temperature sensor. (Fig.20)

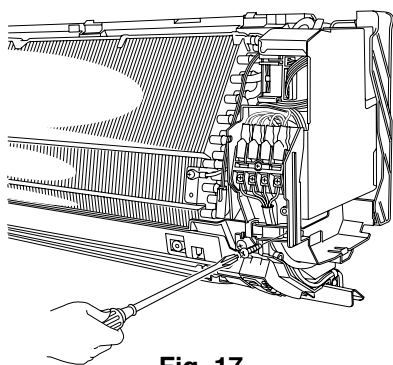

Fig. 17

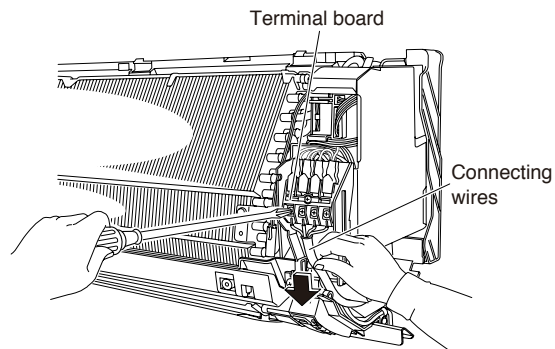

Fig. 18

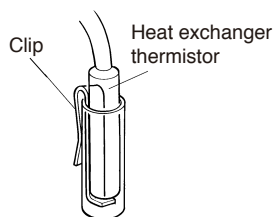

Fig. 19

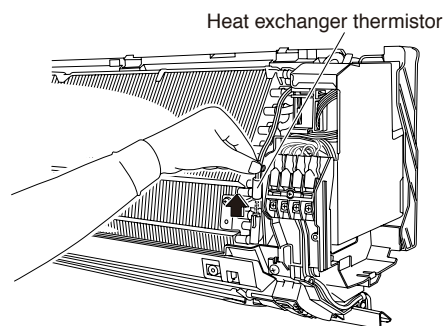

Fig. 20

- (4) Remove a screw on the terminal board. (Fig.21)

- (5) Remove fan motor signal wire. (Fig.22)

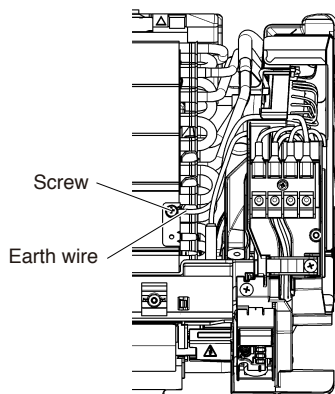

Fig. 21

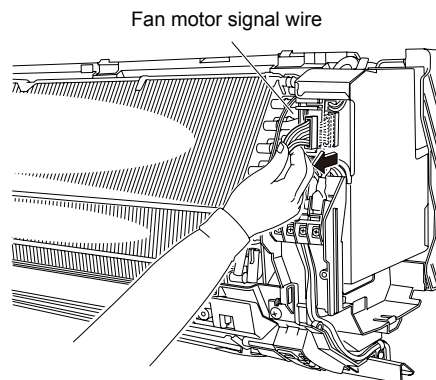
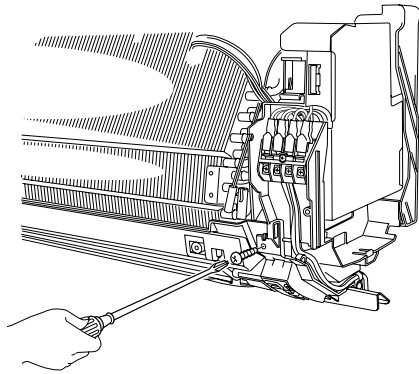

Fig. 22



(6) Remove a screw on the electrical box. (Fig.23)

(7) Pull up the electrical box forward to remove. (Fig.24)



**Fig. 23**

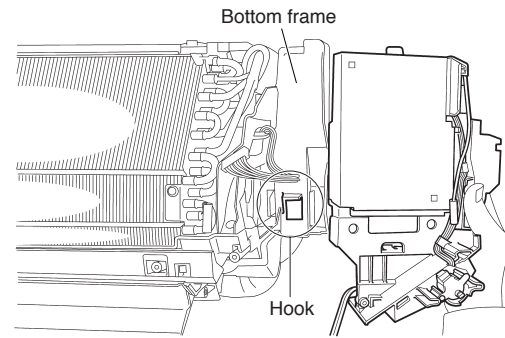

**Fig. 24**

### 9-1-7. Removing the shield plate

(1) Unfasten the hooks at the upper 2 positions of the shield plate. (Fig.25)

(2) Unfasten the hook at the lower position, and remove the shield plate 1. (Fig.26)

(3) Lift the shield plate 2 and unfasten the 2 hooks. (Fig.27)

(4) Slide the shield plate 2 and remove it. (Fig.27)

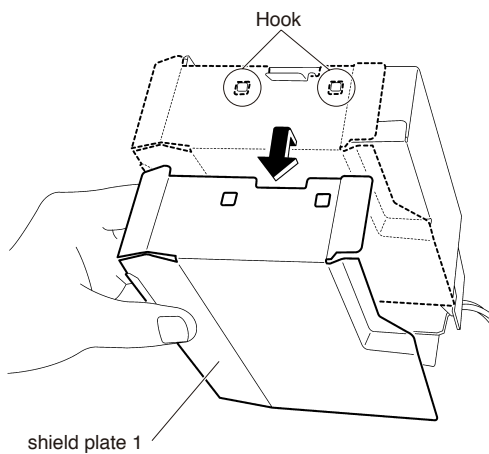

**Fig. 25**

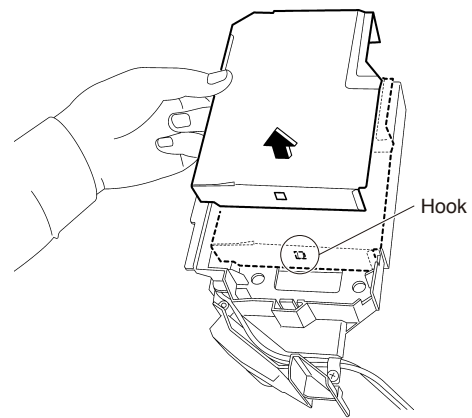

**Fig. 26**

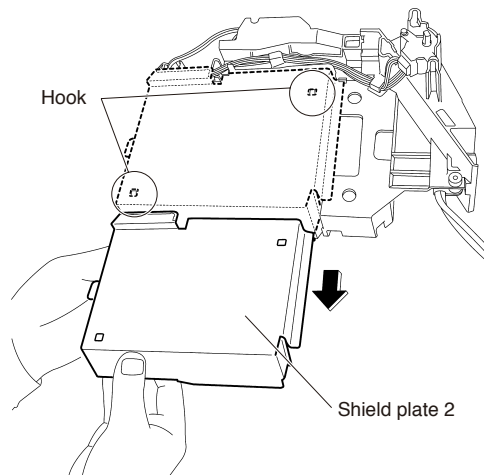

**Fig. 27**

- (5) Take off wiring terminal. (Fig.28)
- (6) Remove display P.C.Board assy. (Fig.29)
- (7) Remove flap motor. (Fig.30 and Fig31)

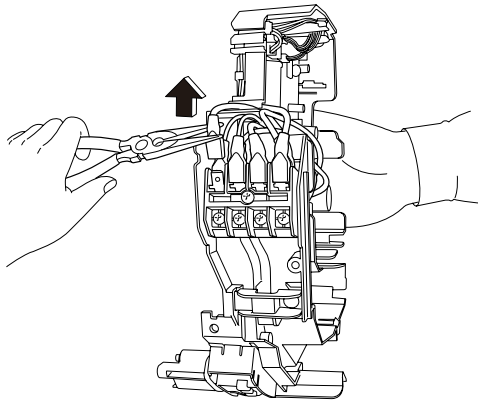

Fig. 28

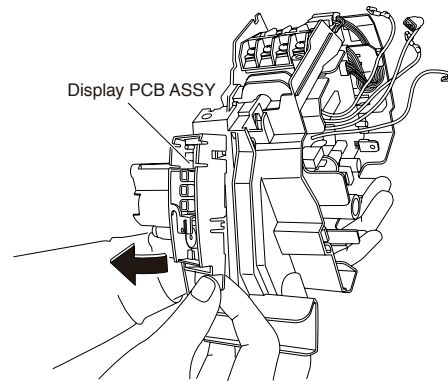

Fig. 29

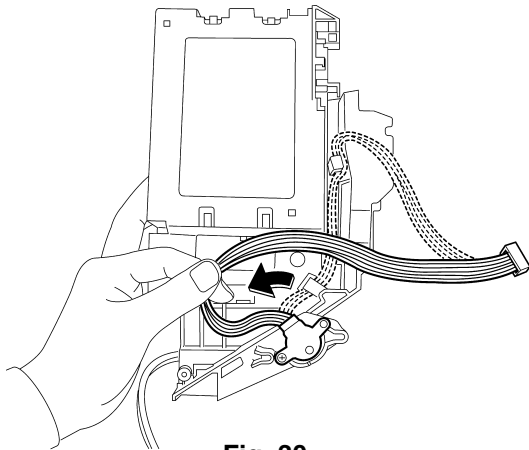

Fig. 30

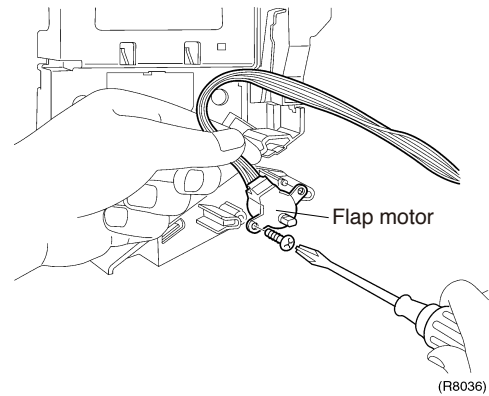

Fig. 31

- (8) To remove the control P.C.Board unfasten the 2 hooks at the upper part from the rear side. (Fig.32)
- NOTE** The control P.C.Board is integrated with the power supply P.C.Board.

- (9) Lift up the upper part of the control P.C.Board and remove it. (Fig.33)

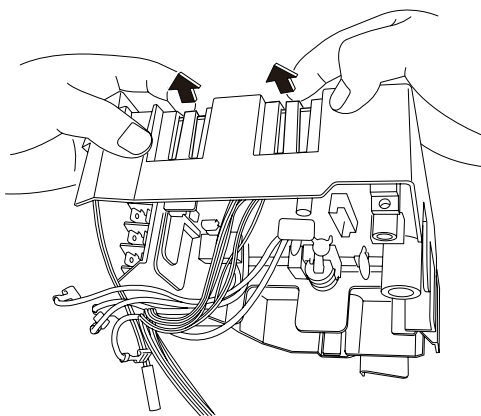

Fig. 32

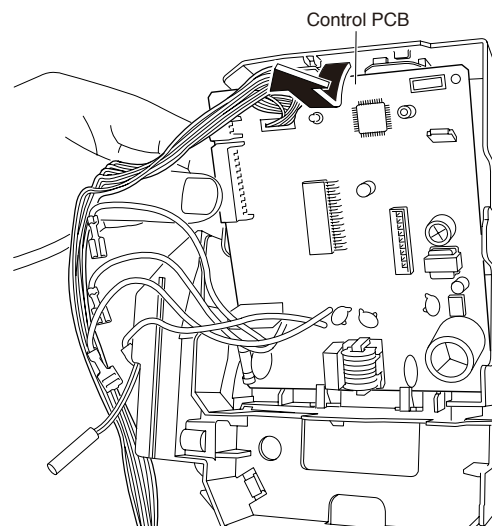





Fig. 33

## 9-1-8. Disconnecting the refrigerant piping

- (1) Lift the indoor unit by a wooden base. (Fig.34)

 <b>Caution</b>	<b>If gas leaks, repair the spot of leaking, then collect all refrigerant from the unit. After conducting vacuum drying, recharge proper amount of refrigerant.</b>	
--	---	---

 <b>Caution</b>	<b>Do not mix any gas (including air) other than the specified refrigerant (R-410A) into refrigerant cycle. If air or other contaminants mix with the gas, pressure will become extremely high in the refrigerating cycle, which may cause a unit breakdown or personal injuries.</b>	
--	---	---

- (2) Place a plastic sheet under the drain pan so that the residual water in the drain will not make the floor wet. (Fig.35)

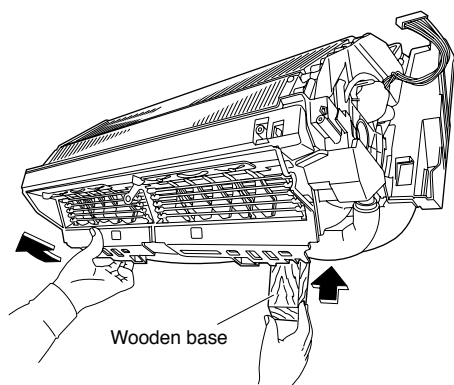

Fig. 34

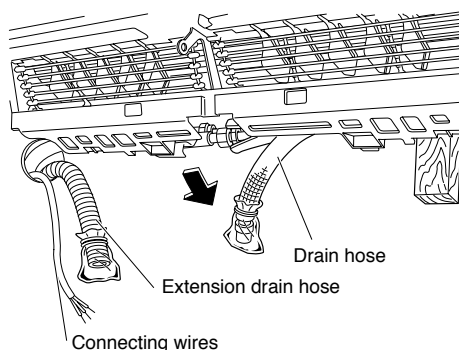

Fig. 35

- (3) Disconnect the flare nut for wide tube by 2 wrenches. (Fig.36)

**NOTE** In case that a drain hose is buried inside a wall, remove it after the drain hose in the wall is pulled out.

- (4) Disconnect the flare nut for narrow tube by 2 wrenches. (Fig.37)

**NOTE** When disconnecting tubes, cover every nozzle with caps so as not to let dust and moisture in.

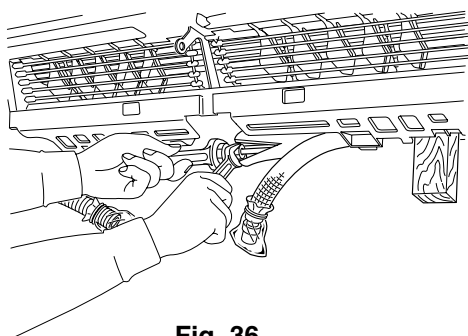

Fig. 36

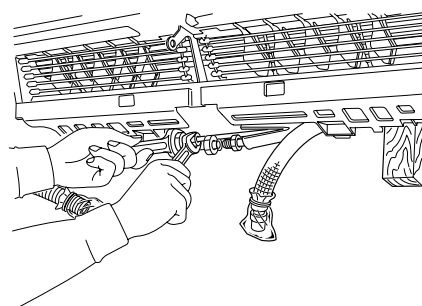

Fig. 37

## 9-1-9. Removing the indoor unit

- (1) Remove the indoor unit from the installation plate. (Fig.38)
- (2) Release the hook of the piping fixture on the back of the unit. (Fig.39, Fig.40 and Fig.41)

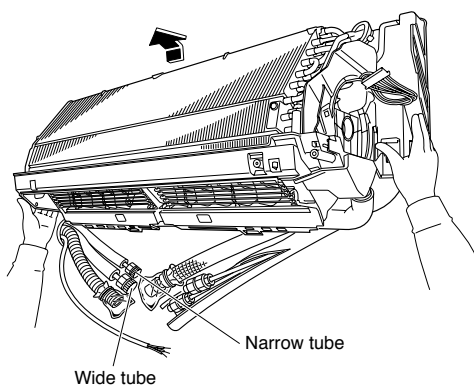

Fig. 38

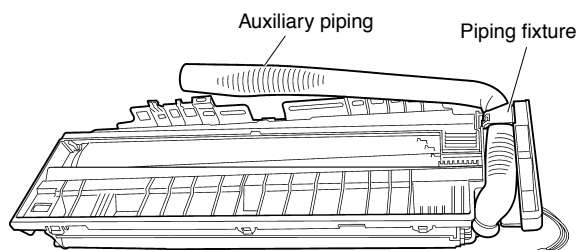

Fig. 39

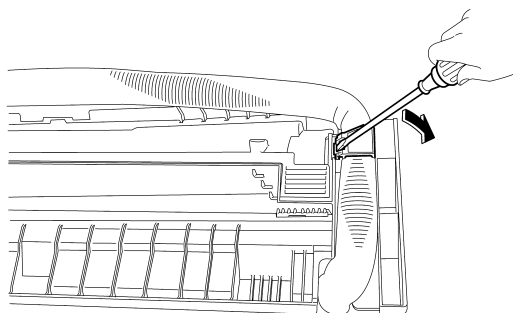

Fig. 40

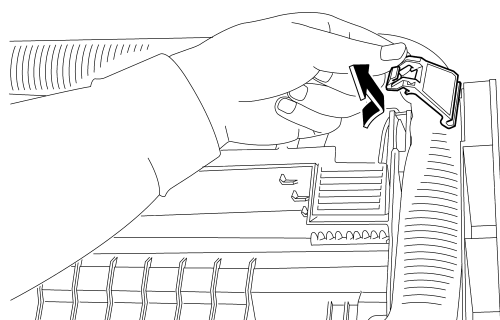

Fig. 41

- (3) Loosen the 2 screws, in the right and the left, which fix the heatexchanger. (Fig.42)

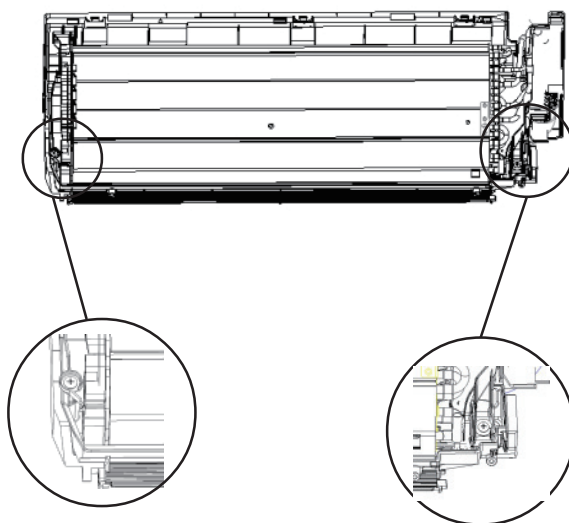

Fig. 42

(4) Widen the auxiliary piping to the extent of 10° to 20°. (Fig.43)

(5) Pull the heat exchanger to the front side to undo the hooks completely, and then lift it. (Fig.44)

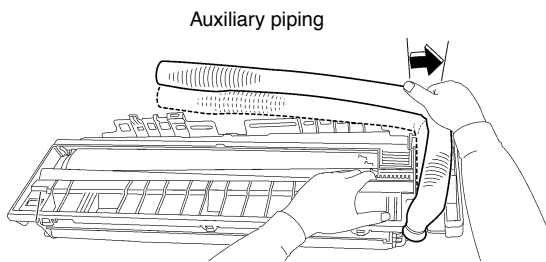

Fig. 43

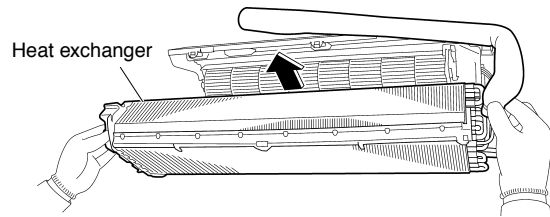

Fig. 44

### 9-1-10. Removing the cross flow fan motor (Fig.45)

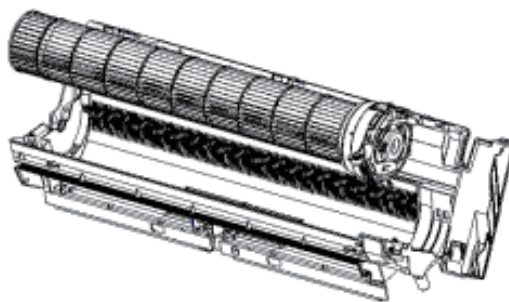

Fig. 45

### 9-1-11. Removing the ring of bearing (Fig.46 and Fig.47)

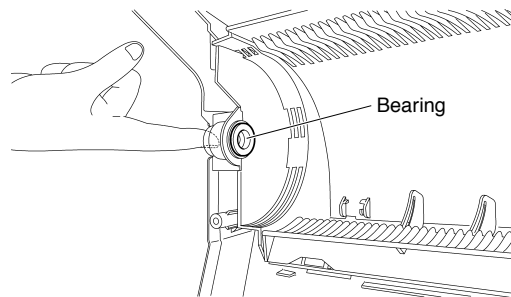

Fig. 46

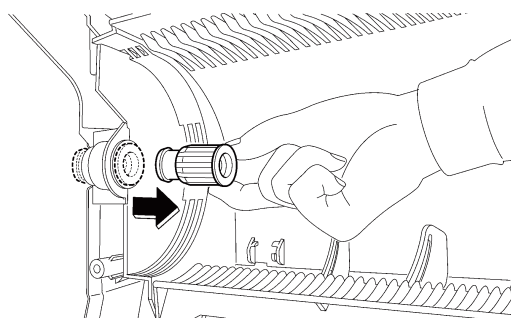
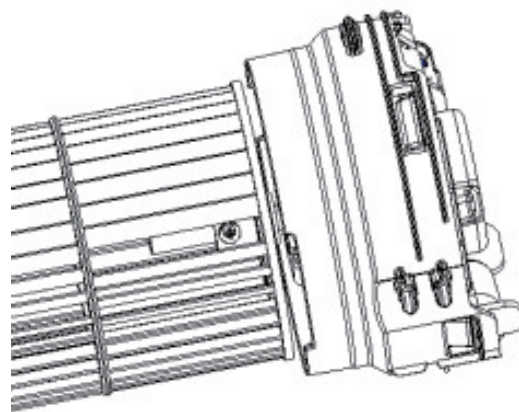

Fig. 47

**9-1-12. Removing the cross flow fan and motor sub-assy screw (Fig.48)**



**Fig. 48**

**9-1-13. Removing the motor sub-assy (Fig.49)**



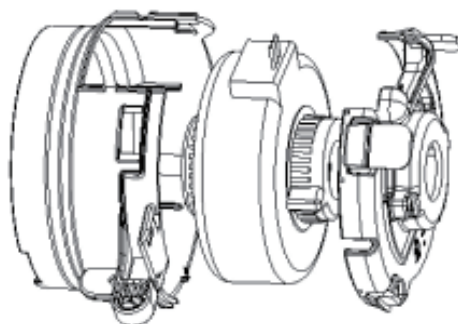

**Fig. 49**

**9-1-14. Removing the fan motor (Fig.50)**



**Fig. 50**

## 9-2. Disassembly Procedure of Outdoor Unit

 <b>Warning</b>	To avoid electrical shock hazard, be sure to disconnect all power and wait 10 minutes or more before attempting to disassemble the unit.	
--	--	---

### 9-2-1. Removing the stop valve cover

- (1) Loosen the screw of the stop valve cover. (Fig.51 and Fig.52)  
Pull down the stop valve cover and remove it.

**NOTE** The stop valve cover has 5 hooks.

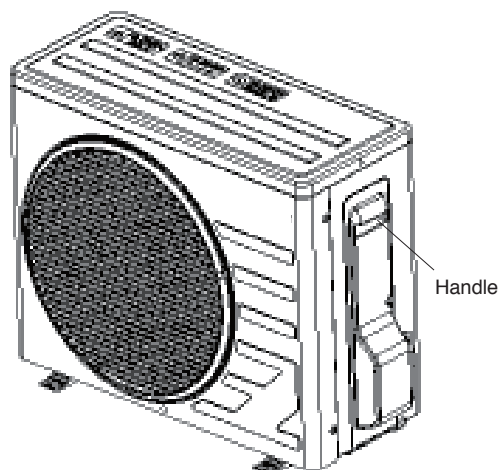

Fig. 51

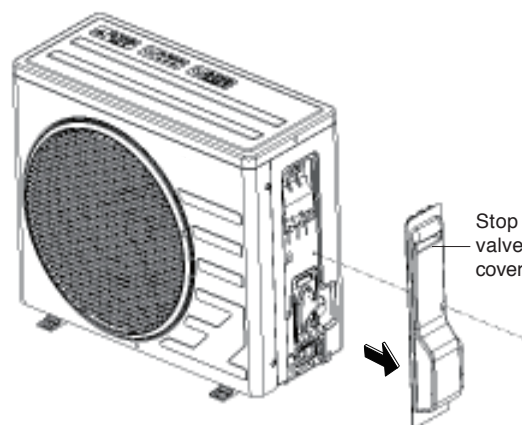

Fig. 52

### 9-2-2. Removing air filters

- (1) Loosen the 3 screws (front, right and left) and lift the top panel. (Fig.53)
- (2) Loosen a screw and remove the discharge grill. (Fig.54)

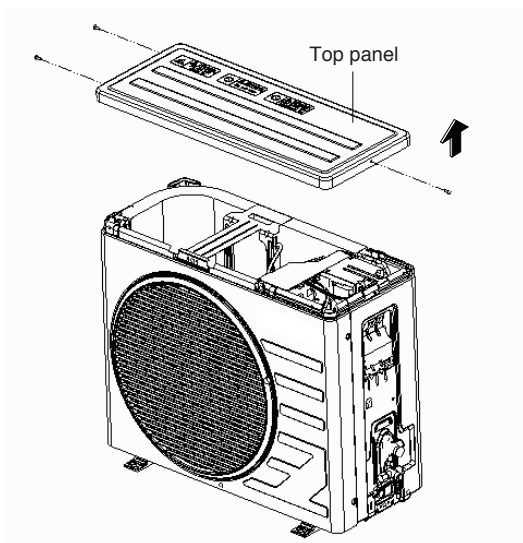

Fig. 53

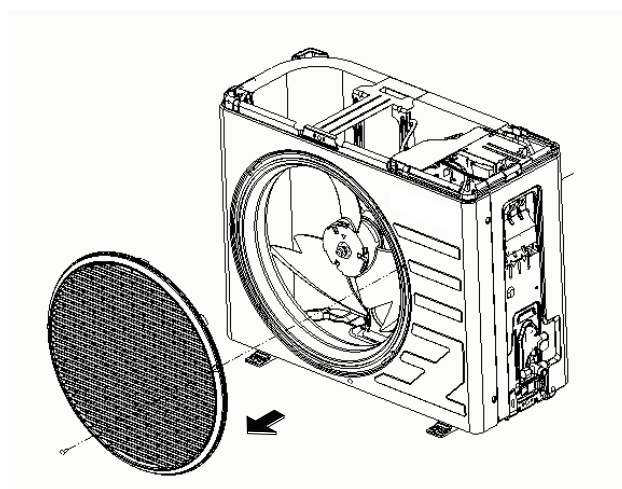

Fig. 54

(3) Loosen the 5 screws of front panel. (Fig.55)

Lift the front panel and remove it while pushing the right side panel inwards.

(4) Remove the 5 screws from the edge of right side board and lift to remove the right side board. (Fig.56)

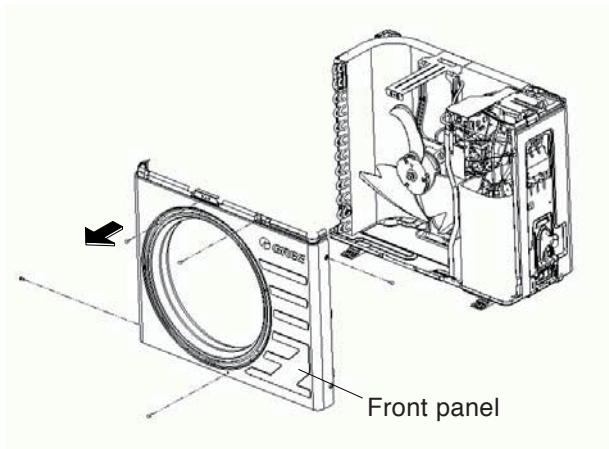

Fig. 55

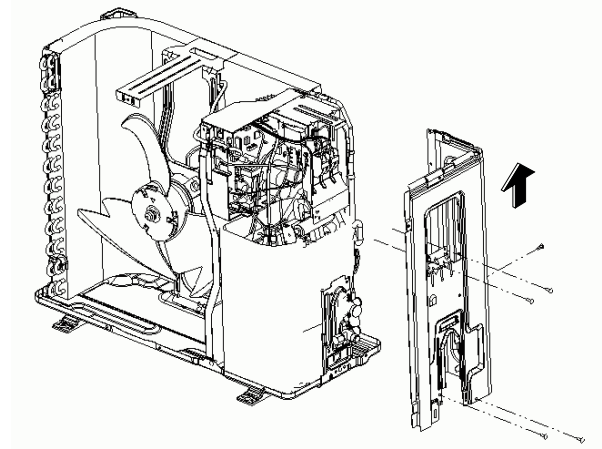

Fig. 56

### 9-2-3. Removing the fan motor

(1) Remove the screw of the fan and then remove the propeller fan. (Fig.57)

**NOTE** The screw has reverse winding.

(2) Remove the 4 tapping screws fixing the motor. (Fig.58)

Pull out the lead out wire and remove the motor.

Remove the 2 tapping screws fixing the motor support and lift to remove the motor support.

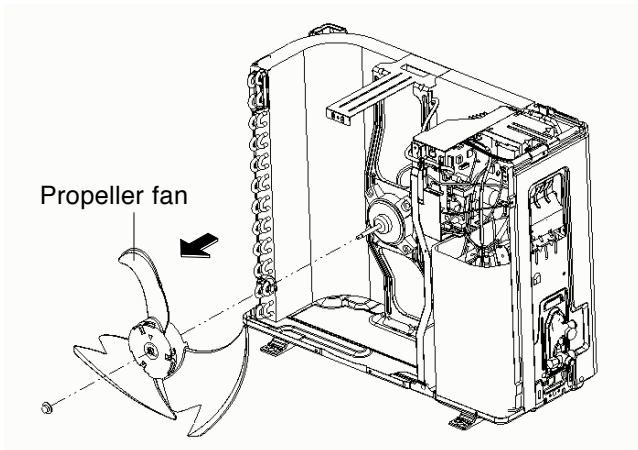

Fig. 57

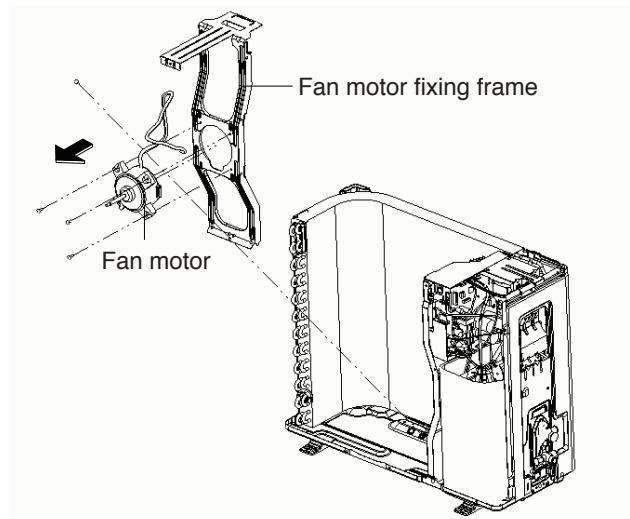

Fig. 58



#### 9-2-4. Removing the electrical box

- (1) Remove the 2 screws fixing the cover of electrical box.  
Lift to remove the cover.  
Remove the screws fixing the electrical box subassembly.  
Loosen the wire and disconnect the terminal.  
Lift to remove the electrical box subassembly. (Fig.59)

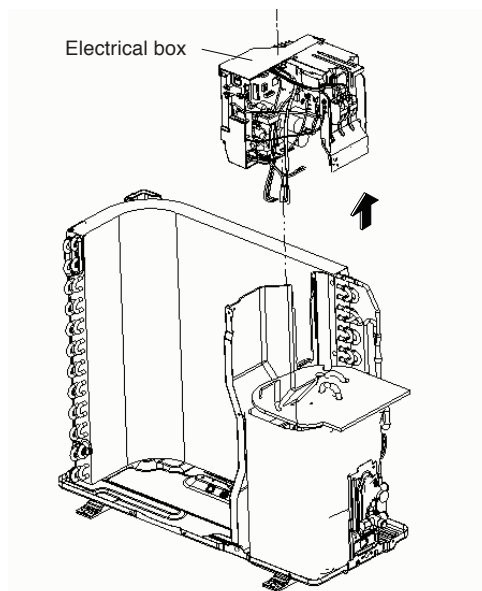

Fig. 59

#### 9-2-5. Removing the partition plate.

- (1) Loosen the 2 screws. (Fig.60)  
**NOTE** The partition plate is fixed to the bottom frame with a hook.
- (2) Lift and pull the partition plate to remove.

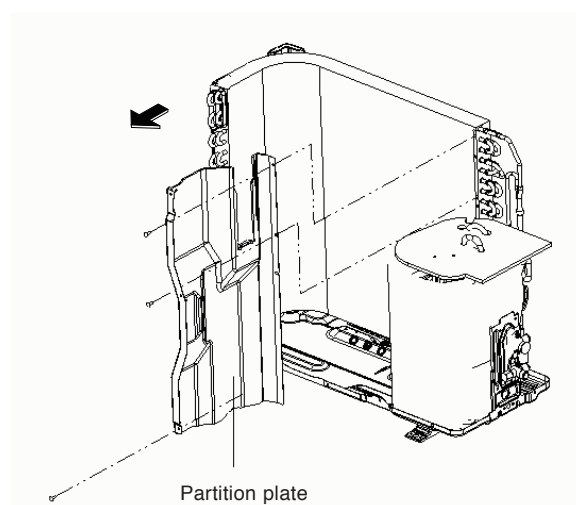

Fig. 60

## 9-2-6. Removing the sound blanket

- (1) Lift and remove the sound blanket (top). (Fig.61)
- (2) Unite the strings and open the sound blanket.
- (3) Lift and remove the sound blanket (body) as it is opened.
- (4) Pull the sound blanket out. (Fig.62)

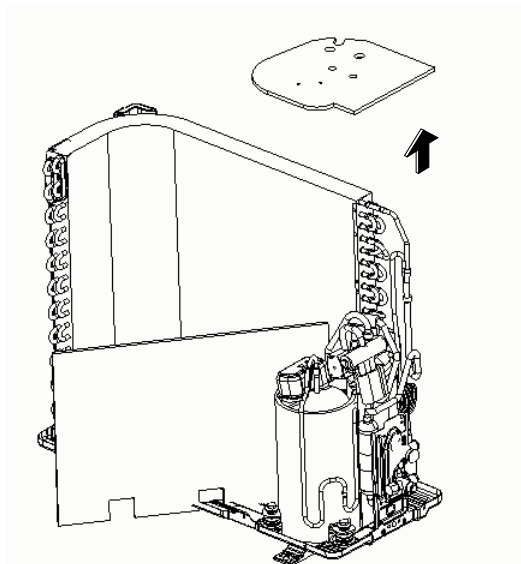

Fig. 61

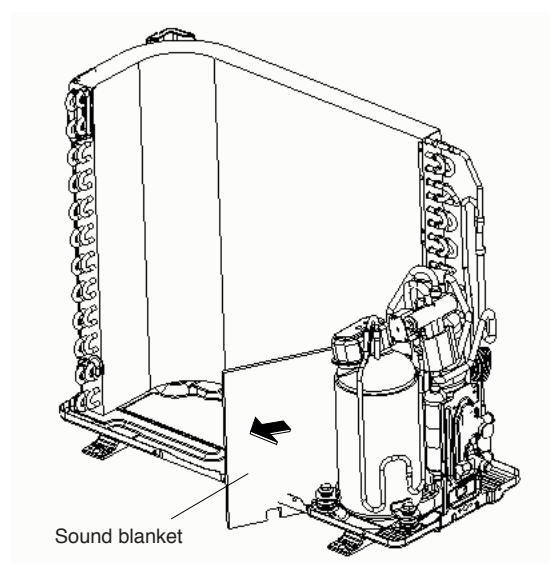



Fig. 62

## 9-2-7. Removing the four way valve coil

 <b>Caution</b>	Be careful about the four way valve, pipes and so on, which were heated up by a gas brazing machine, so as not to get burnt your hands.	
--	---	---

- (1) Loosen the screw of the four way valve coil and remove the four way valve coil. (Fig.63)  
**NOTE** 1. Provide a protective sheet or a steel plate so that the brazing flame can not influence peripheries.  
2. Be careful so as not to break the pipes by pressing it excessively by pliers when withdrawing it.

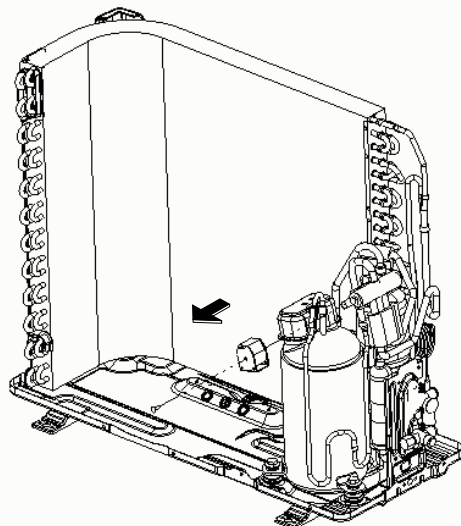

Fig. 63

## 9-2-8. Disassembling the compressor section

- (1) Solder off the welding spot of capillary, valve and outlet pipe of heatexchanger.
- (2) Remove the 2 screws fixing the wide tube valve. (Fig.64)  
Solder off the welding spot connecting wide tube valve and air return pipe, and remove the wide tube valve.  
**NOTE** It is necessary to warp the wide tube valve when soldering off the welding spot.

Remove the 2 screws fixing the narrow tube valve. Solder off the welding spot connecting narrow tube valve and remove the narrow tube valve.

- (3) Solder off the pipe connected with the compressor. (Fig.65)  
Remove the 3 footing screws of the compressor and remove the compressor. (Fig.66)

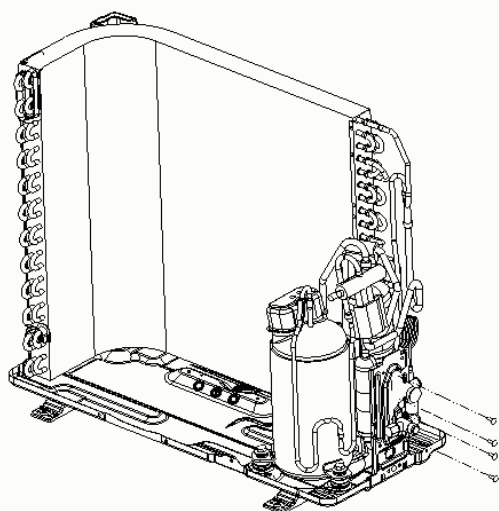

Fig. 64

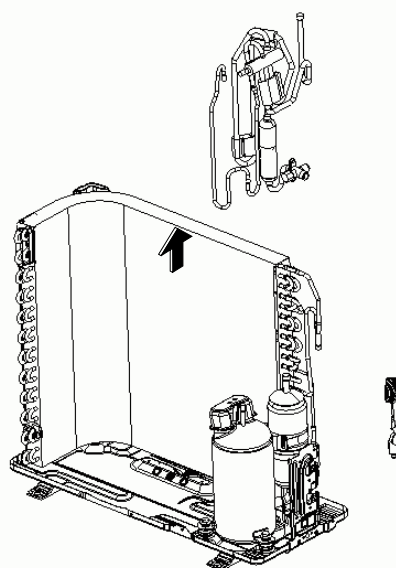

Fig. 65

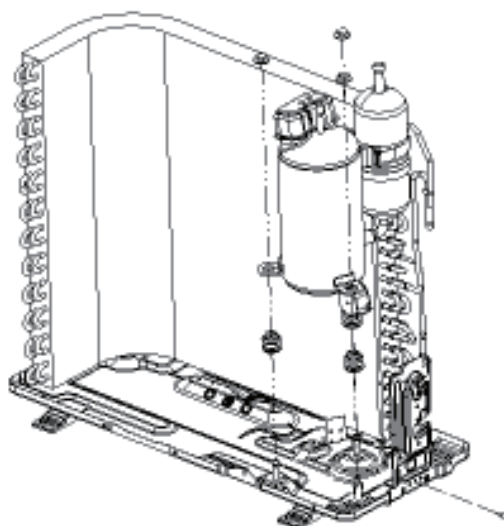

Fig. 66

# 10. REFRIGERANT R410A: SPECIAL PRECAUTIONS WHEN SERVICING UNIT

## 10-1. Characteristics of New Refrigerant R410A

### 10-1-1. What is New Refrigerant R410A?

R410A is a new refrigerant that contains two types of pseudo-non-azeotropic refrigerant mixture. Its refrigeration capacity and energy efficiency are about the same level as the conventional refrigerant, R22.

### 10-1-2. Components (mixing proportions)

HFC32 (50%) / HFC125 (50%)

### 10-1-3. Characteristics

- Less toxic, more chemically stable refrigerant
- The composition of refrigerant R410A changes whether it is in a gaseous phase or liquid phase. Thus, when there is a refrigerant leak the basic performance of the air conditioner may be degraded because of a change in composition of the remaining refrigerant. **Therefore, do not add new refrigerant.** Instead, recover the remaining refrigerant with the refrigerant recovery unit. Then, after evacuation, totally recharge the specified amount of refrigerant with the new refrigerant at its normal mixed composition state (in liquid phase).
- When refrigerant R410A is used, the composition will differ depending on whether it is in gaseous or liquid phase, and the basic performance of the air conditioner will be degraded if it is charged while the refrigerant is in gaseous state. **Thus, always charge the refrigerant while it is in liquid phase.**



**CAUTION**

**Ether-type oil is used for compressor oil for R410A-type units, which is different from the mineral oil used for R22. Thus more attention to moisture prevention and faster replacement work compared with conventional models are required.**

## 10-2. Checklist before Servicing

Use a clutch-type flare tool for R410A or the conventional flare tool. Note that sizes of the resultant flares differ between these two tools. Where a conventional flare tool is used, make sure to observe A Specification (amount of extrusion) by using the flare spacer.

Diameter of tube D	Specification A	
	Flare tool for R410A	Conventional flare tool (for R22)
Dia.6.35 mm (1/4")	0 to 0.5 mm	1.2 mm
Dia.9.52 mm (3/8")		
Dia.12.7 mm (1/2")		
Dia.15.88 mm (5/8")		

### ● Size of flare

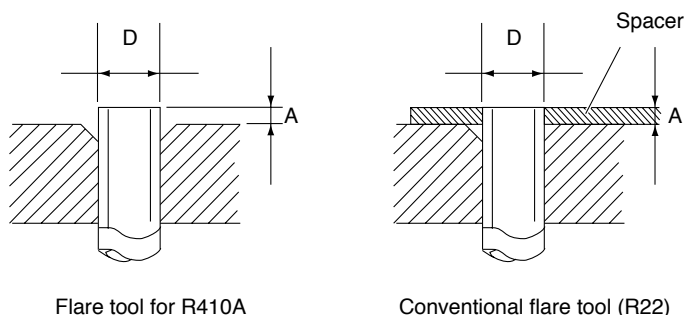

- **Tubing precautions**

- Refrigerant R410A is more easily affected by dust or moisture compared with R22, thus be sure to temporarily cover the ends of the tubing with caps or tape prior to installation.

Never use 0.7mm-thick copper tubing or tubing which is less than 0.8mm in thickness, since air conditioners with R410A are subject to higher pressure than those using R22 and R407C.

- **No addition of compressor oil for R410A**

No additional charge of compressor oil is permitted.

- **No use of refrigerant other than R410A**

Never use a refrigerant other than R410A.

- **If refrigerant R410A is exposed to fire**

Through welding, etc., toxic gas may be released when R410A refrigerant is exposed to fire. Therefore, be sure to provide ample ventilation during installation work.

- **Caution in case of R410A leak**

Check for possible leak points with the special leak detector for R410A. If a leak occurs inside the room, immediately provide thorough ventilation.

### 10-3. Tools Specifically for R410A

- For servicing, use the following tools for R410A

Tool Distinction	Tool Name
Tools specifically for R410A	<ul style="list-style-type: none"> <li>● Gauge manifold</li> <li>● Charging hose</li> <li>● Gas leak detector</li> <li>● Refrigerant cylinder</li> <li>● Charging cylinder</li> <li>● Refrigerant recovery unit</li> <li>● Vacuum pump with anti-reverse flow (*1) (Solenoid valve-installed type, which prevents oil from flowing back into the unit when the power is off, is recommended.)</li> <li>● Vacuum pump (*2)...can be used if the following adapter is attached.</li> <li>● Vacuum pump adapter (reverse-flow prevention adapter) (*3). (Solenoid valve-installed adapter attached to a conventional vacuum pump.)</li> <li>● Electronic scale for charging refrigerant</li> <li>● Flare tool</li> </ul>
Tools which can be commonly used for R22, R407C, and R410A	<ul style="list-style-type: none"> <li>● Bender</li> <li>● Torque wrench</li> <li>● Cutter, reamer</li> <li>● Welding tool, nitrogen gas cylinder</li> </ul>



**CAUTION**

- The above tools specifically for R410A must not be used for R22 and R407C. Doing so will cause malfunction of the unit.
- For the above vacuum pump (\*1, \*2) and vacuum pump adapter (\*3), those for R22-type units can be used for R410A-type. However, they must be used exclusively for R410A and never alternately with R22 and R407C.
- To prevent other refrigerants (R22, R407C) from being mistakenly charged to this unit, shape and external diameter of the service port screw has been altered.  
 <External diameter of service port> R410A : 7.94 mm (5/16")  
 R22, R407C : 6.35 mm (1/4")

### 10-4. Tubing Installation Procedures

When the tubes are connected, **always apply HAB oil on the flare portions to improve the sealing of tubing.**

The following is the **HAB oil** generally used:

Esso: ZERICE S32

**NOTE** For details on tubing installation procedures, refer to the installation manuals attached to the indoor unit and outdoor unit.

## 10-5. In Case of Compressor Malfunction



### CAUTION

- Should the compressor malfunction, be sure to make the switch to a replacement compressor as quickly as possible.
- Use only the tools indicated exclusively for R410A. → See "10-3. Tools Specifically for R410A."

### 10-5-1. Procedure for Replacing Compressor

#### (1) Recovering refrigerant

- Any remaining refrigerant inside the unit should not be released to the atmosphere, but recovered using the refrigerant recovery unit for R410A.
- Do not reuse the recovered refrigerant, since it will contain impurities.

#### (2) Replacing Compressor

- Soon after removing seals of both discharge and suction tubes of the new compressor, replace it quickly.

#### (3) Checking for sealing

- Use nitrogen gas for the pressurized gas, and never use a refrigerant other than R410A. Also do not use oxygen or any flammable gas.

#### (4) Evacuation

- Use a solenoid valve-installed vacuum pump so that even if power is cut off in the middle of evacuation of air due to a power interruption, the valve will prevent the pump oil from flowing back.
- The equipment may be damaged if moisture remains in the tubing, thus carry out the evacuation thoroughly.
- When using a vacuum pump with exhaust air volume more than 25L/min. and ultimate vacuum pressure rate of 0.05Torr.

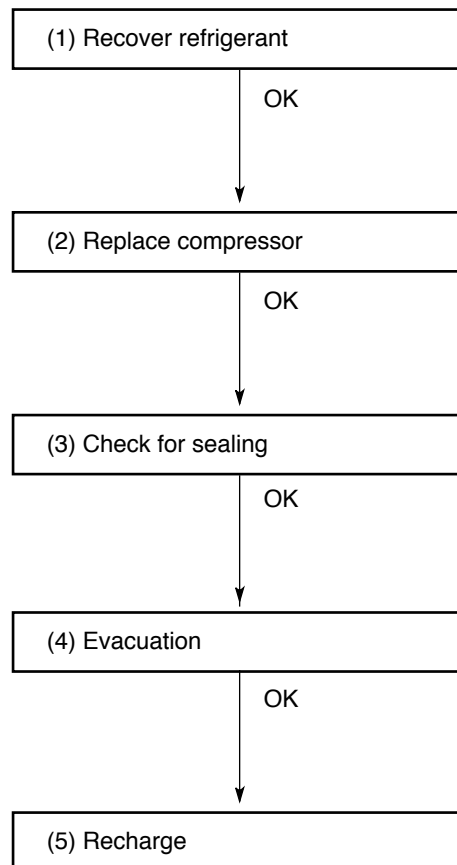

#### Standard time for evacuation

Length of tubing	Less than 10 meters	More than 10 meters
Evacuation time	More than 10 minutes	More than 15 minutes

## (5) Recharging

- **Be sure to charge the specified amount of refrigerant in liquid state** using the service port of the wide tube service valve. The proper amount is listed on the unit's nameplate.

When the entire amount cannot be charged all at once, charge gradually while operating the unit in Cooling Operation.



**CAUTION**

**Never charge a large amount of liquid refrigerant at once to the unit. This may cause damage to the compressor.**

- When charging with a refrigerant cylinder, use an electronic scale for charging refrigerant. In this case, if the volume of refrigerant in the cylinder becomes less than 20% of the fully-charged amount, the composition of the refrigerant starts to change. Thus, **do not use the refrigerant if the amount in the charging cylinder is less than 20%.**

Also, charge the minimum necessary amount to the charging cylinder before using it to charge the air conditioning unit.

### Example:

In case of charging refrigerant to a unit requiring 0.76Kg using a capacity of a 10Kg cylinder, the minimum necessary amount for the cylinder is:

$$0.76 + 10 \times 0.20 = 2.76\text{Kg}$$

**For the remaining refrigerant, refer to the instructions of the refrigerant manufacturer.**

- If using a charging cylinder, transfer the specified amount of liquid refrigerant from the refrigerant cylinder to the charging cylinder.

Prepare an evacuated charging cylinder beforehand.



**CAUTION**

- **To prevent the composition of R410A from changing, never bleed the refrigerant gas into the atmosphere while transferring the refrigerant. (Fig. 3)**

**Do not use the refrigerant if the amount in the charging cylinder is less than 20%.**

## Configuration and characteristics of cylinders

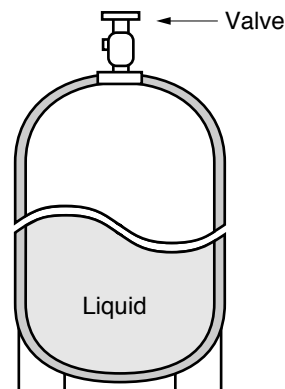

### Single valve

Charge liquid refrigerant with cylinder in up-side-down position.

Fig. 1

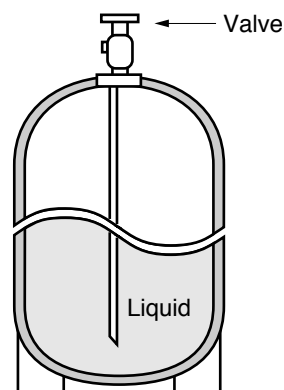

### Single valve (with siphon tube)

Charge with cylinder in normal position.

Fig. 2

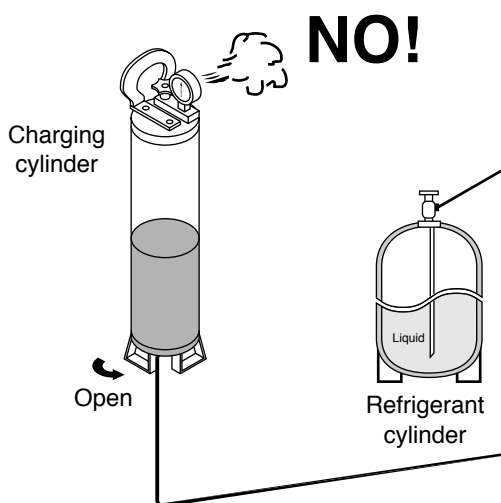

Fig. 3



## 10-6. In Case Refrigerant is Leaking



### CAUTION

Never attempt to charge additional refrigerant when refrigerant has been leaking from the unit. Follow the procedure described below to locate points of leaks and carry out repairs, then recharge the refrigerant.

#### (1) Detecting Leaks

- Use the detector for R410A to locate refrigerant leak points.

#### (2) Recovering refrigerant

- Never release the gas to the atmosphere; recover residual refrigerant using the refrigerant recovery unit for R410A, instead.
- Do not reuse the recovered refrigerant because its composition will have been altered.

#### (3) Welding leaking points

- Confirm again that no residual refrigerant exists in the unit before starting welding.
- Weld securely using flux and wax for R410A.
- Prevent oxide film from forming inside the tubes utilizing substitution with nitrogen (N<sub>2</sub>) in the refrigerant circuit of the unit. Leave ends of tubes open during welding.

#### (4) Checking for sealing

- Use nitrogen gas for the pressurized gas, and never use a refrigerant other than R410A. Also do not use oxygen or any flammable gas.

#### (5) Evacuation

- **Use a solenoid valve-installed vacuum pump** so that even if power is cut off in the middle of evacuation of air due to a power interruption, the valve will prevent the pump oil from flowing back.
- The equipment may be damaged if moisture remains in the tubing, thus carry out the evacuation thoroughly.
- When using a vacuum pump with exhaust air volume more than 25L/min. and ultimate vacuum pressure rate of 0.05Torr.

#### Standard time for evacuation

Length of tubing	Less than 10 meters	More than 10 meters
Evacuation time	More than 10 minutes	More than 15 minutes

#### (6) Recharging

- Recharge unit in the same manner explained on the previous page "(5) Recharging."

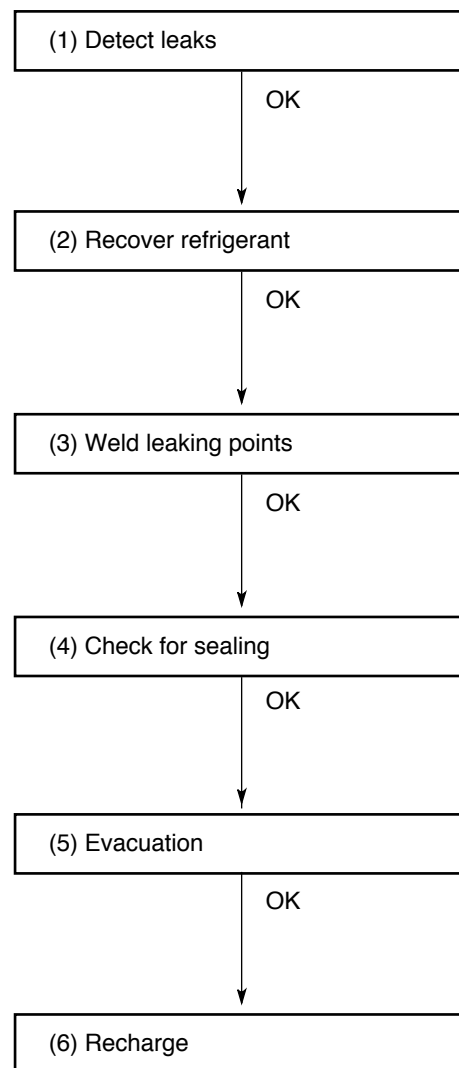

## 10-7. Charging Additional Refrigerant

### 10-7-1. When Tubes are Extended

- Observe the proper amount of refrigerant as stated in this service manual or the installation manual that came with the indoor unit. **Charge additional refrigerant in liquid state only.**



CAUTION

**Never charge additional refrigerant if refrigerant is leaking from the unit. Follow instructions given in "10-6. In Case Refrigerant is Leaking" and completely carry out repairs. Only then should you recharge the refrigerant.**

## 10-8. Retro-Fitting Existing Systems

### 10-8-1. Use of Existing Units

- **Never use new refrigerant R410A for existing units which use R22.** This will cause the air conditioner to operate improperly and may result in a hazardous condition.

### 10-8-2. Use of Existing Tubing

- If replacing an older unit that used refrigerant R22 with a R410A unit, **do not use its existing tubing.** Instead, completely new tubing must be used.

# **APPENDIX A** INSTRUCTION MANUAL

## **SAP-KRV9AEH + SAP-CRV9AEH SAP-KRV12AEH + SAP-CRV12AEH**

(OI-852-6-4181-180-00-1)

**SAP-KRV9AEH**  
**SAP-KRV12AEH**

COOL/DRY/HEAT Model

**SANYO**

**This air conditioner uses  
the new refrigerant R410A.**

**INSTRUCTION MANUAL**

Inverter-Controlled Split System Air Conditioner

EG

**MANUAL DE INSTRUCCIONES**

Acondicionador de aire de dos unidades  
controlado por inverter

ES

**MODE D'EMPLOI**

Climatiseur de type séparé contrôlé par inverseur

F

**BEDIENUNGSANLEITUNG**

Splitsystem-Klimagerät mit Inverter-Steuerung

D

**ISTRUZIONI PER L'USO**

Condizionatore d'aria con sistema separato  
controllato dall'invertitore

I

**MANUAL DE INSTRUÇÕES**

Aparelho de ar condicionado do sistema split com  
inversor controlado

P

**ΕΓΧΕΙΡΙΔΙΟ ΟΔΗΓΙΩΝ**

Κλιματιστικό συστήματος χωρισμού και  
ελεγχόμενο από αντιστροφέα

GR

Save These Instructions!  
Guarde estas instrucciones  
Conserver ce mode d'emploi  
Bewahren Sie bitte diese  
Bedienungsanleitung auf.  
Conservate queste istruzioni  
Guarde estas instruções  
Φυλάξτε τις οδηγίες αυτές

Pub. OI-85264181180001

© SANYO 2010

**SANYO Electric Co., Ltd.**  
Osaka, Japan

## FEATURES

This air conditioner is an inverter type unit that automatically adjusts capability as appropriate. Details on these functions are provided below; refer to these descriptions when using the air conditioner.

 **24-hour Clock with ON/OFF Program Timer**  
The remote control unit allows you to set a wide variety of timer-based operations including automatic ON/OFF with timer setting, same-time ON/OFF every day, ON timer, OFF timer and Combination timer.

 **Mild Dry**  
By coupling the compressor and fan operation, intermittent drying can be precisely controlled according to room temperature so that air is efficiently dehumidified.

 **Auto Clean**  
Fan operates when the unit is stopped to prevent the generation of mold and odors within the indoor unit.

 **Humanized Sleep Function**  
Temperature gently rises or falls automatically to maintain comfortable room temperature, saving energy.

 **Rapid Cooling (Heating)**  
The high-efficiency system cools quickly while maintaining high EER/COP.

 **Super Quiet**  
Specially designed air vent efficiently reduces noise.

 **Turbo**  
Powerfully cools the room.

 **Automatic Fan Operation**  
Convenient microprocessor control automatically adjusts fan speed to High, Medium or Low, according to room temperature, to maintain a comfortable airflow throughout the room.

 **Air Sweep Control**  
The air sweep function automatically moves the air outlet flap up and down, directing air in a sweeping motion around the room and ensuring comfort in every corner.

 **Automatic Restart Function for Power Failure**  
Even when power failure occurs, preset programmed operation is reactivated once power resumes.

 **Self Diagnosis**  
Error code is displayed for fast and easy maintenance, should a problem occur.

 **Low Voltage Startup (Min.198V)**  
The unit starts safely even when the voltage is below the rated voltage.

 **Child Lock**  
Remote controller keys are lockable to prevent misoperation.

 **Blue Fin**  
Anti-corrosion blue fin is more effective than a common coil.

## CONTENTS

	Page
FEATURES .....	2
PRODUCT INFORMATION .....	3
ALERT SYMBOLS .....	3
INSTALLATION LOCATION .....	3
ELECTRICAL REQUIREMENTS.....	3
SAFETY INSTRUCTIONS.....	3
1. USAGE POINTS .....	4
2. NAMES AND FUNCTIONS OF PARTS .....	6
3. OPERATION OF WIRELESS REMOTE CONTROL UNIT .....	7
4. CLEANING AND CARE .....	16
5. ADJUSTING THE AIRFLOW DIRECTION CORRECTLY .....	18
6. TROUBLESHOOTING .....	18

## PRODUCT INFORMATION

If you have problems or questions concerning your Air Conditioner, you will need the following information. Model and serial numbers are on the nameplate on the bottom of the cabinet.

Model No. \_\_\_\_\_

Serial No. \_\_\_\_\_

Date of purchase \_\_\_\_\_

Dealer's address \_\_\_\_\_

Phone number \_\_\_\_\_

### DECLARATION OF CONFORMITY

This product is marked « **CE** » as it satisfies EEC Directive No. 2004/108/EC, 2006/95/EC and 93/68/EEC. This declaration will become void in case of mis-usage and/or from non observance though partial of Manufacturer's installation and/or operating instructions.

## ALERT SYMBOLS

The following symbols used in this manual, alert you to potentially dangerous conditions to users, service personnel or the appliance:



**WARNING**

This symbol refers to a hazard or unsafe practice which can result in severe personal injury or death.



**CAUTION**

This symbol refers to a hazard or unsafe practice which can result in personal injury or product or property damage.

## INSTALLATION LOCATION

- We recommend that this air conditioner be installed properly by qualified installation technicians in accordance with the Installation Instructions provided with the unit.
- Before installation, check that the voltage of the electric supply in your home or office is the same as the voltage shown on the nameplate.



**WARNING**

- Do not install this air conditioner where there are fumes or flammable gases, or in an extremely humid space such as a greenhouse.
- Do not install the air conditioner where excessively high heat-generating objects are placed.

### Avoid:

To protect the air conditioner from heavy corrosion, avoid installing the outdoor unit where salty sea water can splash directly onto it or in sulphurous air near a spa.

## ELECTRICAL REQUIREMENTS

1. All wiring must conform to the local electrical codes. Consult your dealer or a qualified electrician for details.
2. Each unit must be properly grounded with a ground (or earth) wire or through the supply wiring.
3. Wiring must be done by a qualified electrician.

## SAFETY INSTRUCTIONS

- Read this Instruction Manual carefully before using this air conditioner. If you still have any difficulties or problems, consult your dealer for help.
- This air conditioner is designed to give you comfortable room conditions. Use this only for its intended purpose as described in this Instruction Manual.



**WARNING**

- Never use or store gasoline or other flammable vapor or liquid near the air conditioner — it is very dangerous.
- This air conditioner has no ventilator for intaking fresh air from outdoors. You must open doors or windows frequently when you use gas or oil heating appliances in the same room, which consume a lot of oxygen from the air. Otherwise there is a risk of suffocation in an extreme case.



**CAUTION**

- Do not turn the air conditioner on and off from the power mains switch. Use the ON/OFF operation button.
- Do not stick anything into the air outlet of the outdoor unit. This is dangerous because the fan is rotating at high speed.
- Do not let children play with the air conditioner.
- Do not cool or heat the room too much if babies or invalids are present.

---

# 1. USAGE POINTS

## 1.1 Working Principle and Special Functions for Cooling

### Principle:

An air conditioner (cooling) absorbs room heat and transmits and discharges it outdoors, thereby decreasing the ambient indoor room temperature. Its cooling capacity will decrease relative to an increase in the outdoor ambient temperature.

### Anti-freezing Function:

If the unit is running in COOL mode and at a low temperature, frost will form on the heat exchanger; when the indoor heat exchanger temperature decreases to below 0°C, the micro-computer of the indoor unit will stop running the compressor to protect the unit.

## 1.2 Working Principle and Special Functions for Heating

### Principle:

1. An air conditioner (heating) absorbs heat from outdoors and transmits it indoors, thereby increasing the indoor room temperature. Its heating capacity will decrease relative to a decrease in the outdoor ambient temperature.
2. If the outdoor temperature is lower than the room temperature, please operate the system with other heating/ventilating equipment.

### Defrosting:

1. When the outdoor temperature is low and there is high humidity, after the unit runs for a while, frost will form on the outdoor unit and affect the heating function. At this time, the auto-defrosting function will turn on, and the heating operation will stop for 8-10 minutes.
2. While the auto-defrosting function is operating, both the fan motors of the indoor and outdoor units will stop operating.
3. While the defrosting function is operating, the indoor indicator flashes and the outdoor unit may emit vapor. This is due to the defrosting and is not a malfunction.
4. After defrosting has finished, the heating process will resume automatically.

### Cold Draft Prevention:

In "HEAT" mode, the indoor blower will not act under the following 3 statuses, until the heat exchanger reaches a certain temperature. This is to prevent cool air from blowing. (Within 2 minutes)

1. When heating starts.
2. After auto-defrosting has finished.
3. Heating under low ambient temperature

### Gentle Breeze:

Under the following conditions, the indoor unit may produce a gentle breeze, and the guide louver may rotate to a predetermined position:

1. In "Heat" mode with the unit turned on, until the compressor starts operating
2. In "Heat" mode with the temperature at the set value and the compressor has stopped running at about 1 minute

# 1. USAGE POINTS

## 1.3 Working Temperature Range

	Temperature	Indoor Air Temperature	Outdoor Air Temperature
COOLING	Max.	32°C DB / 23°C WB	43°C DB / 26°C WB
	Min.	21°C DB / 15°C WB	21°C DB
HEATING	Max.	27°C DB	24°C DB / 18°C WB
	Min.	20°C DB	-7°C DB / -8°C WB

EG



## 2. NAMES AND FUNCTIONS OF PARTS

### Indoor Unit

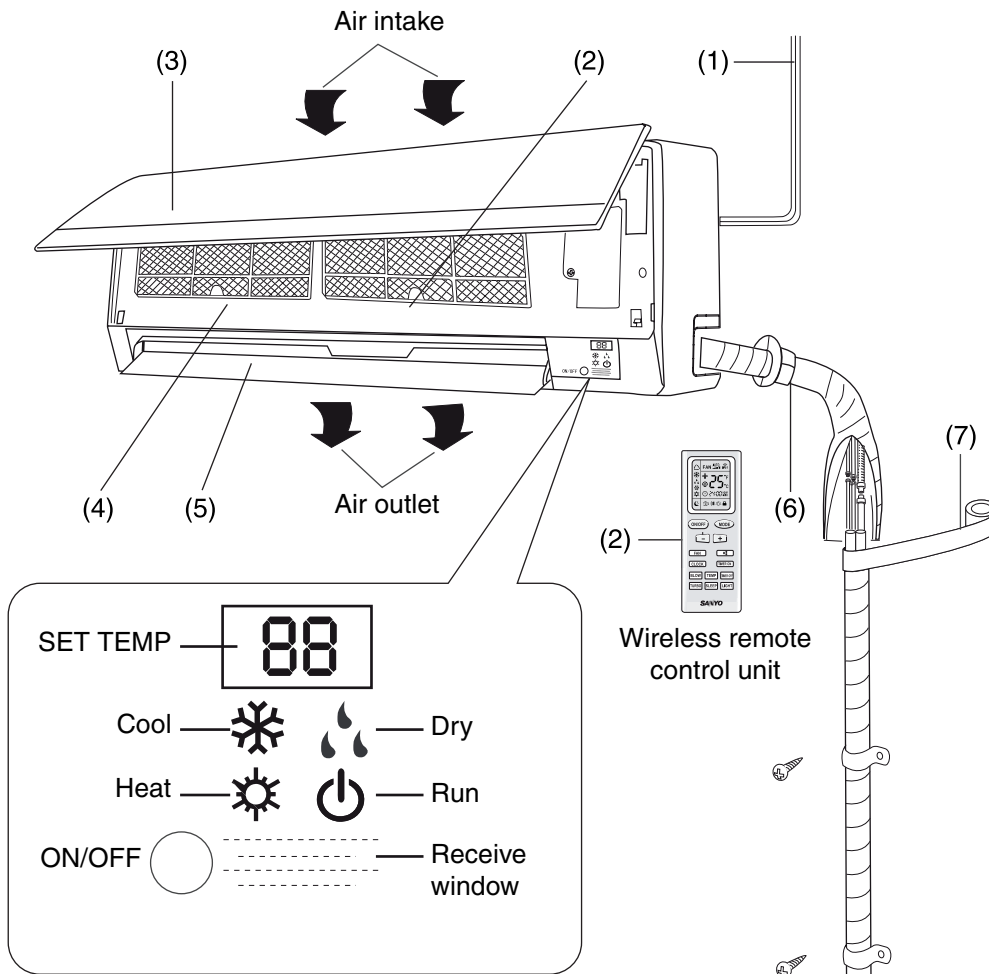

### Outdoor Unit

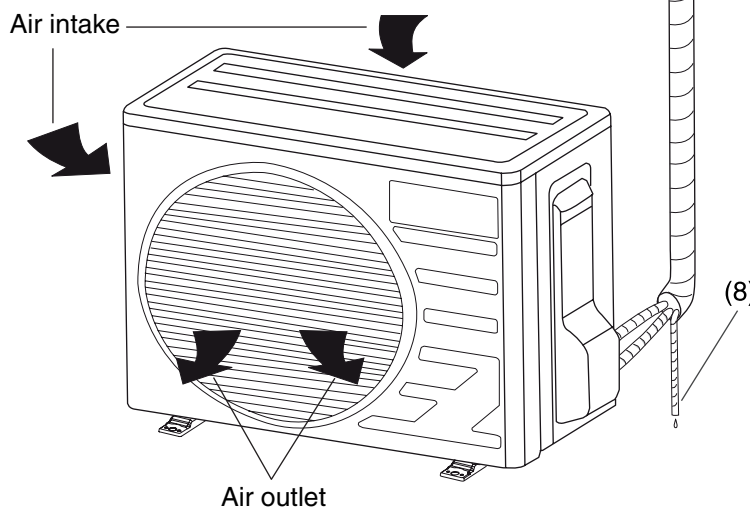

S/n	Part Name
(1)	Power cable
(2)	Remote control unit
(3)	Front panel
(4)	Filter
(5)	Guide louver
(6)	Wall pipe
(7)	Bind tape
(8)	Drainage pipe

### 3. OPERATION OF WIRELESS REMOTE CONTROL UNIT

#### 3.1 Remote Control Unit (Display)

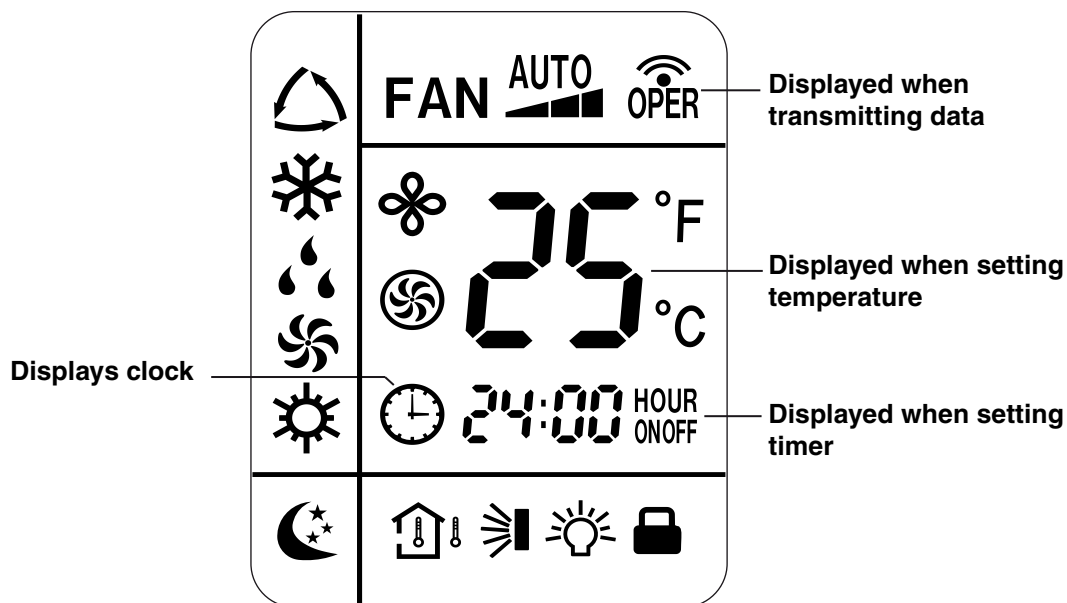

### Symbols

(1) Operation mode		(4) Timer	
AUTO .....		24-hour ON Timer .....	
COOL .....		24hour OFF Timer .....	
DRY .....		(5) Sleep .....	
FAN .....		(6) Confirmation of transmission.....	
HEAT .....		(7) Clock indication .....	
(2) Fan speed		(8) Sweep indication .....	
Automatic operation .....		(9) Light .....	
HIGH .....		(10) Blow .....	
MID.....		(11) Turbo .....	
LOW .....		(12) Temperature .....	
(3) Set temperature		(13) Lock.....	
16 – 30°C			
When set to 23°C .....			

### 3. OPERATION OF WIRELESS REMOTE CONTROL UNIT

#### 3.2 Remote Control Unit Functions

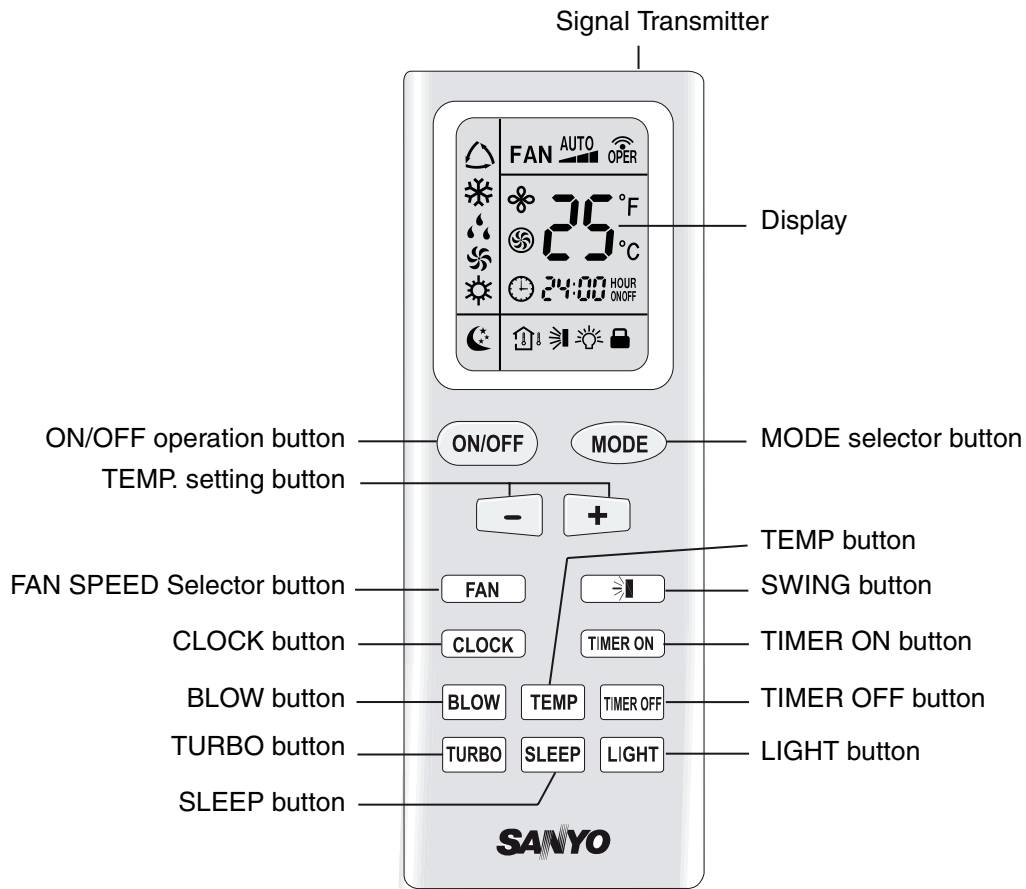

<b>Transmitter</b>	When you press the buttons on the remote control unit, the  mark appears in the display to transmit the setting changes to the receiver in the air conditioner.
<b>Display</b>	Information on the operating conditions is displayed while the remote control unit is turned on. If the unit is turned off, only the current time and the operation mode temperature that has been set are displayed.
<b>ON/OFF operation button</b>	This button is for turning the air conditioner ON and OFF.
<b>MODE selector button</b> (AUTO) (COOL) (DRY) (FAN) (HEAT)	To select "AUTO" "COOL" "DRY" "FAN" or "HEAT" mode. : In this setting, the air conditioner calculates the difference between the thermostat setting and the room temperature and automatically switches to "COOL" or "HEAT" mode as appropriate. : The air conditioner makes the room cooler. : The air conditioner reduces the humidity in the room. : The air conditioner runs the indoor fan only. : The air conditioner makes the room warmer.
<b>(+) / (-) setting buttons</b>	: Press the (+) button to increase the set temperature; continue pressing for two seconds to quickly increase the set temperature. : Press the (-) button to reduce the set temperature; continue pressing for two seconds to quickly reduce the set temperature.
<b>LOCK / UNLOCK button</b>	: Simultaneously press the   button to lock or unlock the wireless remote control unit.
<b>TIMER ON button</b>	ON : The air conditioner starts at the set time.
<b>TIMER OFF button</b>	OFF : The air conditioner stops at the set time.

### 3. OPERATION OF WIRELESS REMOTE CONTROL UNIT

#### 3.2 Remote Control Unit Functions (Continued)

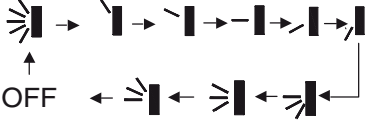
<p><b>FAN SPEED selector button</b></p>	<p>AUTO : The air conditioner automatically decides the fan speeds.</p> <p>▬ : Low fan speed.</p> <p>▬▬ : Medium fan speed.</p> <p>▬▬▬ : High fan speed.</p> 
<p><b>TEMP button</b></p> <p><b>NOTE</b></p>	<p>Press to see the set temperature or indoor temperature that are displayed on the indicator lamp.</p> <p>🏠 : Display the preset temperature.</p> <p>🏠⏱ : Display the indoor ambient temperature (5 seconds)</p> <p><b>The ambient temperature will be displayed for 5 seconds, following which the preset temperature will be displayed.</b></p> <p>🏠⏱ : Current displaying status will not be changed.</p> <p>No Icon : Default display of preset temperature.</p>
<p><b>BLOW button</b></p>	<p>Press to start or stop indoor fan drying indoor components. This function is applicable to “COOL” &amp; “DRY” mode only. In “AUTO,” “FAN,” and “HEAT” mode, “BLOW” function is not available and “BLOW” is not displayed.</p>
<p><b>LIGHT button</b></p>	<p>Press this button to turn ON/OFF indicator light display.</p>
<p><b>TURBO button</b></p>	<p>Press to quickly cool or heat the room with powerful cool or hot air.</p>
<p><b>SLEEP button</b></p>	<p>For details, see “SLEEP MODE” (page 12). When you press this button in the “DRY,” “COOL” or “HEAT” mode, the 🌙 mark appears in the display and the remote control unit will automatically adjust the set temperature to save energy.</p>
<p><b>CLOCK Button</b></p>	<p>Use this button to set the clock.</p> <p><b>How it Works</b></p> <p>Press the CLOCK button once if the 🕒 indicator is not flashing. The 🕒 indication alone flashes. Within 5 seconds, press the +/- button. The time can be set in 1-minute increments. Holding down the button advances the time rapidly in 10-minute increments. Press the CLOCK button again. The 🕒 is displayed, completing the setting of the current time.</p>
<p><b>SWING Button</b></p> <p><b>NOTE</b></p>	<p>Sets the air swing direction to change circularly as below:</p>  <p><b>When the guide louver begins swinging up and down, if swing is turned off, the air guide louver will stop at the current position. (refer to page 14 for more details)</b></p>

### 3. OPERATION OF WIRELESS REMOTE CONTROL UNIT

#### 3.3 General Operation

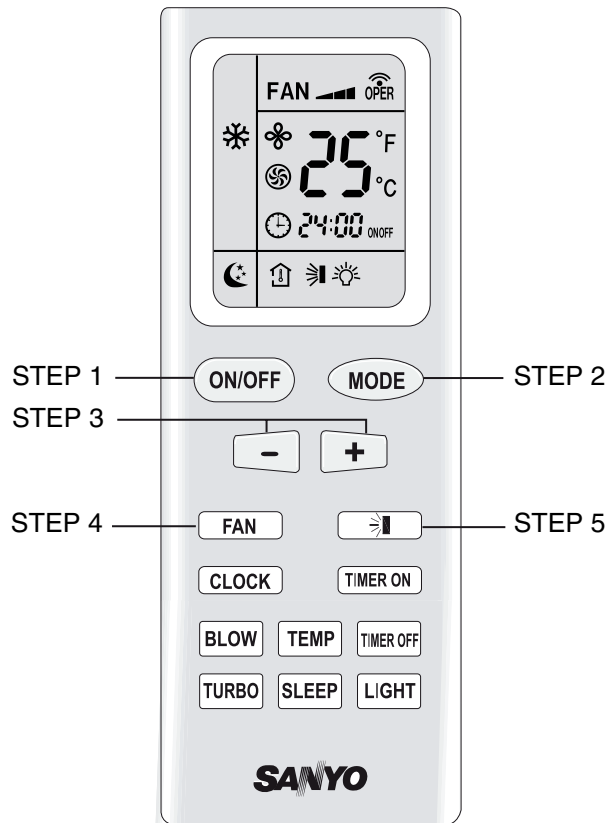

**NOTE** Press the setting buttons as described below and change the settings as desired.

<b>STEP 1</b>	To start the air conditioner, press the ON/OFF operation button.
<b>STEP 2</b>	Press the MODE selector button and select the desired mode. For DRY operation → ☁ For COOLING operation → ❄ For FAN only operation → 🌀 For AUTO operation → ⚙ For HEATING operation → ☀
<b>STEP 3</b>	Press the TEMP. setting buttons to change the temperature setting to the desired temperature. Adjustable temperature range: 30°C (86°F) max.—16°C (61°F) min. In “AUTO” mode, the temperature cannot be adjusted. In “HEAT” mode, the initial value is 28°C (82°F). In other operation, the initial value is to 25°C (77°F).
<b>STEP 4</b>	Set the FAN SPEED selector button to the desired setting. AUTO: Auto fan speed. ◀ : Low fan speed. ◀◀ : Middle fan speed. ◀◀◀ : High fan speed.
<b>NOTE</b>	In Dry mode, the fan speed is automatically set to LOW.
<b>STEP 5</b>	Press the 🌀 button and set the air-blow direction, as desired or automatically.

To STOP the air conditioner, press the ON/OFF operation button again.

### 3. OPERATION OF WIRELESS REMOTE CONTROL UNIT

#### 3.4 Using the 24-Hour “ON” or “OFF” Timer

##### 3.4.1 TIMER ON Mode (Example)

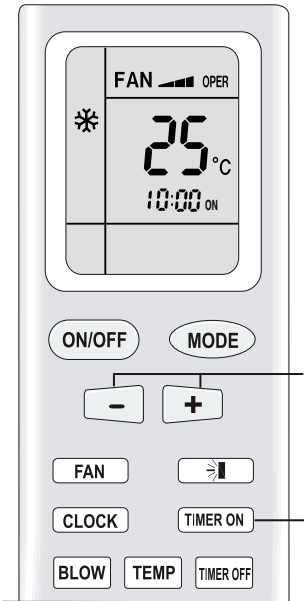

After the length of time set for **TIMER ON** elapses, the unit begins operating.

The display depicted at left indicates that the air conditioner will begin operating in 10 hours.

**Setting procedure:**

<b>STEP 1</b>	Press the “ON/OFF” button and “MODE” button to set the desired operation mode. (See “Operation with the Remote Control Unit”, page 8). Press the “ON/OFF” button again to turn off the unit.
<b>STEP 2</b>	Press the “TIMER ON” button.
<b>STEP 3</b>	Press the “TIMER ON” button (which advances the clock displayed) to set the time at which you want operation to begin. The time can be set for one-minute intervals for 24 hours. Holding down the (+) / (-) button will rapidly change the time value. Press the “TIMER ON” button again to confirm the set time is 10 A.M.

- The display changes immediately to the current time, but ON indication remains.

**Cancellation procedure:** Press the “TIMER ON” button again to cancel.

##### 3.4.2 TIMER OFF Mode (Example)

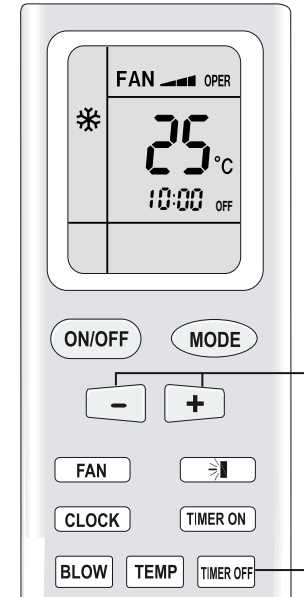

After the length of time set for **TIMER OFF** elapses, the unit stops operating.

The display depicted at left indicates that the air conditioner will stop operating in 10 A.M.

**Setting procedure:**

<b>STEP 1</b>	Press the <b>TIMER OFF</b> button.
<b>STEP 2</b>	Press the “TIMER OFF” button (which advances the clock displayed) to set the time at which you want operation to stop. The time can be set for one-minute intervals for 24 hours. Holding down the (+) / (-) button will rapidly change the time value. Press the “TIMER OFF” button again to confirm the off time is 10 A.M.

- The display changes immediately to the current time, but OFF indication remains.

**Cancellation procedure:** Press the “TIMER OFF” button again.

### 3. OPERATION OF WIRELESS REMOTE CONTROL UNIT

#### 3.5 SLEEP Operation

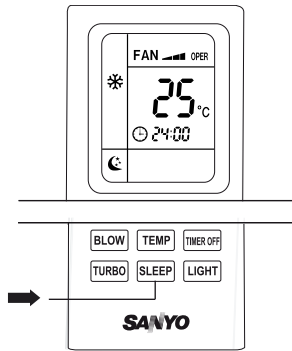

**SLEEP Mode is used for saving energy.**

Press the SLEEP button while operation is on.

The ☾ mark appears in the display.

To release the SLEEP function, press the SLEEP button again.

##### 3.5.1 In Cooling and DRY Modes: (☼ and ☾)

When the SLEEP mode is selected, the air conditioner automatically raises the temperature setting 1°C when 1 hour has passed after the selection was made, and then another 1°C after another 2 hours have passed, regardless of the indoor temperature when SLEEP was selected. The unit will maintain this temperature. This enables you to save energy without sacrificing comfort. This function is convenient when gentle cooling is needed.

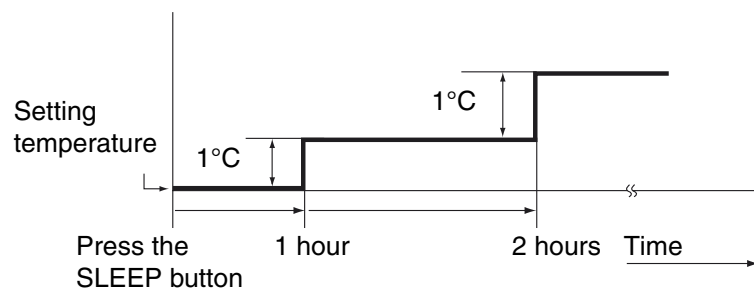

##### 3.5.2 In Heating Mode: (☼)

When the SLEEP mode is selected, the air conditioner automatically lowers the temperature setting 1°C when 1 hour has passed after the selection was made, and then another 1°C after another 2 hours have passed, regardless of the indoor temperature when SLEEP was selected. The unit will maintain this temperature. This enables you to save energy without sacrificing comfort. This function is convenient when gentle heating is needed.

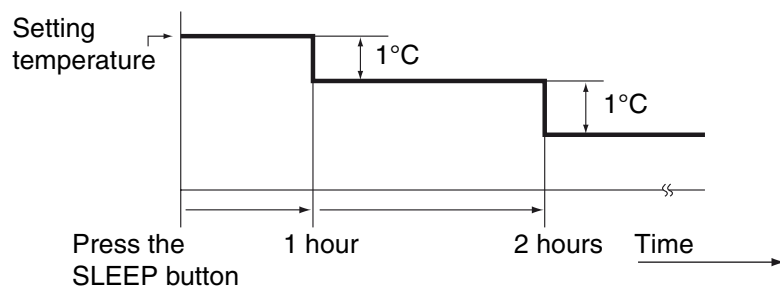

## 3. OPERATION OF WIRELESS REMOTE CONTROL UNIT

### 3.6 “SPECIAL” Features

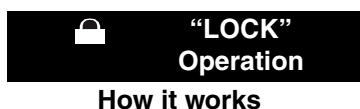
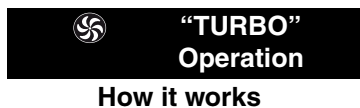

- During DRY operation, the fan speed is automatically set to LOW.
- If the room temperature is 2°C higher than the Set Temperature, the unit will run in COOL mode.
- Once the room temperature reaches  $\pm 2^\circ\text{C}$  of the level that was set, the unit automatically repeats the cycle of compressor turning “ON” for 6 minutes and turning “OFF” for 4 minutes.
- When AUTO mode is selected, the default temperature will be displayed on the LCD, and the unit will automatically adjust to the room temperature, selecting the appropriate operation method and ambient comfort.

This function indicates that moisture on the evaporator of the indoor unit will be dispersed after the unit is stopped to avoid the formation of mold. Once the blow function resumes, the indoor fan will continue running for about 10 minutes at low speed even after the unit is turned off by pressing the ON/OFF button, in which case, pressing the “BLOW” button again will immediately stop the indoor fan.

In “COOL” or “HEAT” mode, if this function is selected, the unit will run at super-high fan speed to cool or heat rapidly to enable the ambient temperature to approach the preset temperature as quickly as possible.

This special button is intended for users who are not accustomed to light while sleeping.

#### Setting the display indicator light to “ON”

When setting the light function, pressing this button will display the mark  on the remote control unit screen. The display indicator light will be turn on if the air conditioner receives this signal.

#### Setting the display indicator light to “OFF”

Canceling the light function will cause the mark  to disappear from the remote control unit screen. The display indicator light will be turn off if the air conditioner receives this signal.

Press “+” and “-” buttons simultaneously to Lock/Unlock the keyboard. If the remote control unit is locked, the  will be displayed, In this case, press any button and the mark will flicker three times. If the keyboard is unlocked, the mark will disappear.





### 3. OPERATION OF WIRELESS REMOTE CONTROL UNIT

#### 3.6 “SPECIAL” Features (Continued)

##### “SWING” Operation How it works

About swing up and down

1. Pressing the swing up and down button continuously for at least 2 seconds will cause the main unit to swing back and forth from up to down. Release the button, and the unit will immediately stop swinging and maintain the current position of the guide louver.
2. In swing up and down mode, when the status is switched from off to , if this button is pressed again 2 seconds later,  status will immediately switch to off status; if pressed again within 2 seconds, swing status change will depend on the circulation sequence outlined below:

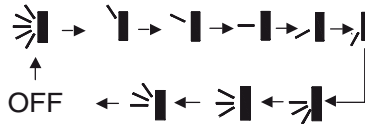

##### “ °F ” / “ °C ” Operation How it works

To switch between Fahrenheit and Centigrade, in unit off status, press “MODE” and “-” buttons simultaneously and then release both buttons immediately to switch between °C and °F.

##### Power Failure During Operation How it works

In the event of power failure, the unit will stop operation. When power resumes, the unit will restart automatically after three minutes.

##### “H1” DEFROSTING Operation How it works

When the unit is in defrost status, “H1” will show on the display indicator board. Even if the unit is turned off with the remote control unit, the unit will not stop defrosting until completed. If there is any change in the set mode with the remote control unit, any new function that is set will not initiate until the defrosting process is finished.

### 3. OPERATION OF WIRELESS REMOTE CONTROL UNIT

#### 3.7 How to Remove and Install Batteries

1. Lightly press the place marked , in the direction of the arrow to remove the back cover of wireless remote control unit. (Fig. 1)
2. Remove the old batteries. (Fig. 1)
3. Insert two new AAA1.5V dry batteries, paying close attention to their polarity. (Fig. 2)
4. Reattach the back cover. (Fig. 2, procedure 4)

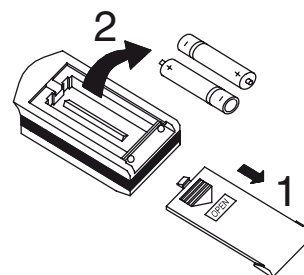

Fig. 1

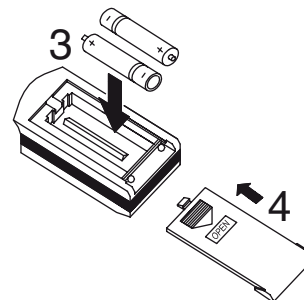

Fig. 2

#### NOTE

- The batteries should last about six months. Replace the batteries when the remote control unit's display fails to light, or when the remote control unit fails to change the air conditioner's settings.
- When changing the batteries, do not use old or incorrect batteries. Use two new leak-proof type-AAA alkaline batteries to avoid causing malfunction of the wireless remote control unit.
- If the wireless remote control unit will not be used for more than one month, remove the batteries to avoid leaking liquid damaging the wireless remote control unit.
- The wireless remote control unit should be placed more than 1 m away from the TV set or stereo sound sets.
- If the remote control unit can not operate normally, please remove and then reinsert the batteries 30 seconds later. If it still cannot operate, change the batteries to new ones.
- The remote control signal can be received up to a distance of about four meters.
- Dispose of used batteries at a designated location in compliance with the applicable local ordinances.

#### 3.8 Using the Remote Control Unit

When using the remote control unit, always point the unit's transmitter head directly at the air conditioner's receiver. (Fig. 3)

(Indoor unit)  
Air conditioner

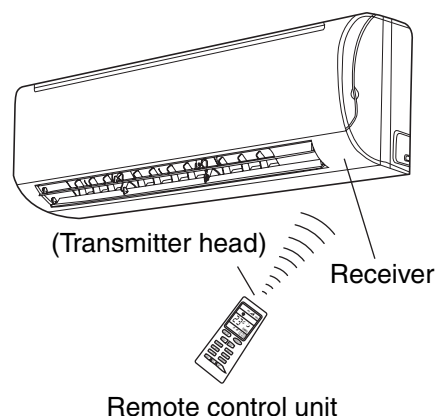

Fig. 3

#### 3.9 Emergency Operation

If the wireless remote control unit is lost or broken, please use the manual switch button. In this case, the unit will run in the "AUTO" mode, but the temperature and fan speed cannot be changed. (Fig. 4)

To open the panel, the manual switch is located on the display box. The operation is shown below:

- **Turn "ON" the Unit:**  
By pressing the button, the unit will immediately run in Auto mode. The microcomputer will select "COOL," "HEAT" or "FAN" mode relative to the indoor temperature and produce a comfortable ambience.
- **Turn "OFF" the Unit:**  
By pressing the button, the unit will stop working.

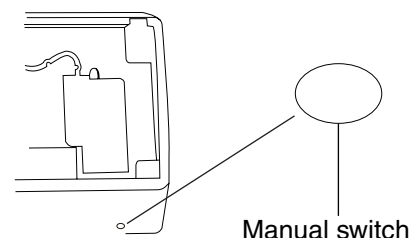

Fig. 4

## 4. CLEANING AND CARE



1. For safety, be sure to turn the air conditioner off and also disconnect the power before cleaning. Or it may cause an electric shock.
2. Never sprinkle water on the indoor unit and the outdoor unit for cleaning because it can cause an electric shock.
3. Volatile liquid (e.g. thinner or gasoline) will damage the air conditioner. (So wipe the units with a dry soft cloth or a cloth slightly moistened with water or cleanser.)

### 4.1 Clean the Front Panel

(Make sure to remove the front panel before cleaning it.)

#### 1. Remove the Front Panel

Open the front panel until it is nearly horizontal, grasp the sections near the front panel arms on both sides, and then remove the panel by pushing the arms towards the inside while pulling the panel towards you. (Fig. 4a, 4b)

#### 2. Washing

Clean with a soft brush, water and neutral detergent, and dry with a clean soft cloth. (Fig. 5)

**NOTE** Do not use water hotter than 45°C to prevent fading or deformation.

#### 3. Replace the Front Panel

Grasp the sections near the front panel arms on both sides, and hold the front panel so that it is nearly horizontal. Push the arm shafts towards the inside so that they come into contact with the top of the indentations on the right and left sides of the air conditioner. Then push firmly until the arm shafts click into place. (Fig. 6a)

- NOTE**
- The arm at the center of the front panel slides into the groove at the front of the unit. (Fig. 6b)
  - After closing the front panel, press firmly on the panel to securely fasten the panel in place.

### 4.2 Cleaning the Air Filters

(Recommended once every 3 months)



1. After removing the filter, some metal edges and the fins are sharp and may cause injury if handled improperly; be especially careful when cleaning these parts.
2. The internal coil and other components of the outdoor unit must be cleaned every year. Consult your dealer or service center.

- NOTE**
1. There are microcomputer components and circuit diagram on the LCD of the front panel.
  2. If dust is significant around the air conditioner, the air filters should be cleaned more often.

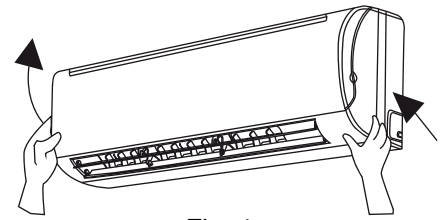

Fig. 4a

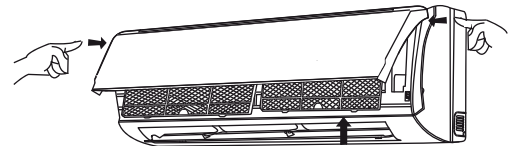

Fig. 4b

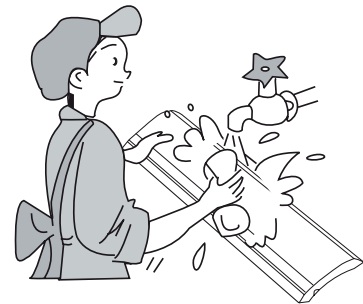

Fig. 5

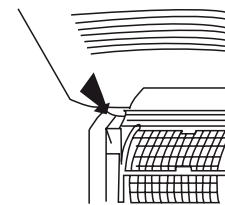

Fig. 6a

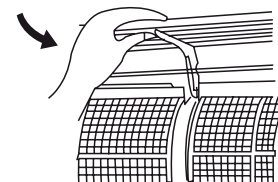

Fig. 6b

## 4. CLEANING AND CARE

### 4.2 Cleaning the Air Filters (Continued)

#### 1. Remove the Air Filters

Pull out the panel at the angle of the bottom grooves on the panel. Next, pull the air filter upward then downward to remove it. (Fig. 7).

#### 2. Cleaning

To clean dust adhering to the filters, either use a vacuum cleaner, or wash them with warm water (water with neutral detergent should be below 45°C) when the filters are very dirty (e.g., oil-stained), and dry them in the shade. (Fig. 8)

**NOTE** Do not use hot water of temperatures above 45°C to prevent fading or deformation. Do not use fire to dry the filter, to avoid fire or deformation.

#### 3. Install the Air Filters

Insert the top of the air filter, and then fit the protrusions on the bottom of the filter all the way into the hooks on the unit.

Press the locations marked by the arrows and close the front panel. (Fig. 9)



**WARNING**

Since the air filter cannot remove harmful gases or vapors nor ventilate the room, open doors or windows frequently when using gas or oil heating appliances. Not doing so carries a risk of suffocation in extreme cases.

### 4.3 Check Before Using

1. Be sure that nothing obstructs the air outlet or intake vents. (Fig.10)
2. Check whether ground wire is properly connected or not.
3. Check whether the batteries of the air conditioner have been changed or not.
4. Check whether the installation stand of the outdoor unit is damaged or not. If damaged, please contact the dealer.

### 4.4 Maintenance After Use

1. Turn main power off.
2. Clean the filter, indoor and outdoor units.
3. Clear dust and obstructions from the outdoor unit.
4. Remove and repaint over any rust on the outdoor unit in order to prevent it from spreading.

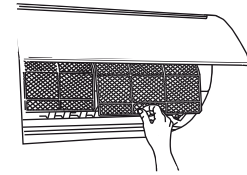

Fig. 7

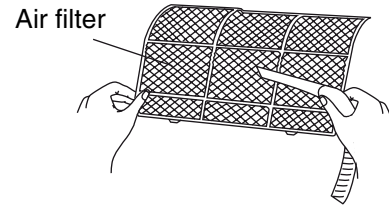

Fig. 8

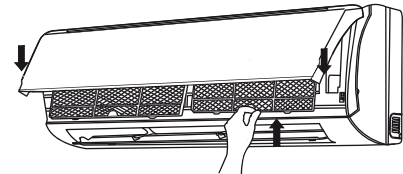

Fig. 9

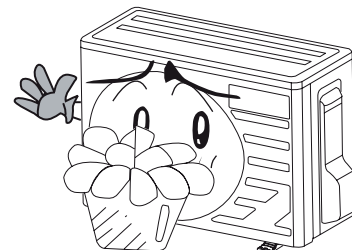
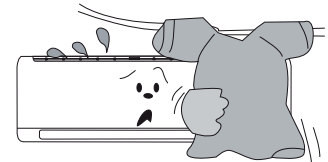

Fig. 10

## 5. ADJUSTING THE AIRFLOW DIRECTION CORRECTLY

### 1. Horizontal

The horizontal airflow can be adjusted by moving the louver with your hand to the left or right.



**CAUTION**

When the humidity is high, the vertical vanes should be in the front position during the cooling or dehumidifying operation. If the vertical vanes are positioned all of the way to the right or left, condensation may begin to form around the air vent and drip down.

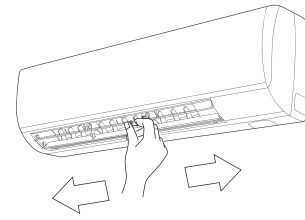

### 2. Vertical

The vertical airflow can be adjusted by moving the flap with the remote control unit.

Use the SWING button to set either the auto sweep or set to the recommended position.



**CAUTION**

- Use the SWING button on the remote control unit to adjust the position of the flap. If you move the flap by hand, the flap position according to the remote control and the actual flap position may no longer match. If this should happen, shut off the unit, wait for the flap to close, and then turn on the unit again; the flap position will now be normal again.
- Do not have the flap pointed down during cooling operation. Condensation may begin to form around the air vent and drip down.

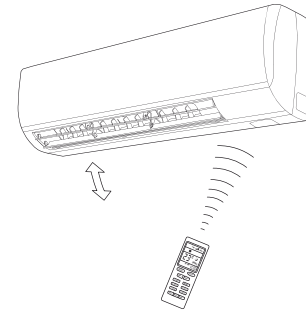

## 6. TROUBLESHOOTING



**CAUTION**

Do not attempt to repair the air conditioner by yourself, as this can cause an electric shock or fire. Please check the following items before asking for repairs, as this can save time and money.

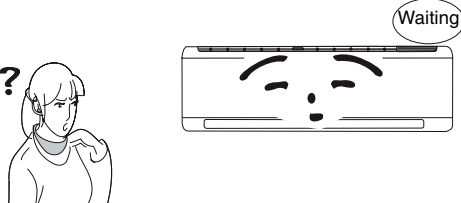
Problem	Solution
<p>Does not operate immediately when the air conditioner is restarted.</p> 	<p>When the air conditioner is restarted immediately after being turned off, the overload protection switch will delay starting for three minutes.</p>

## 6. TROUBLESHOOTING

EG

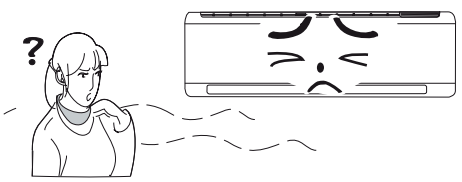
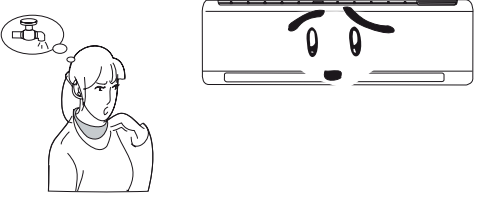
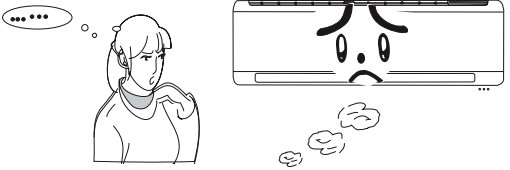
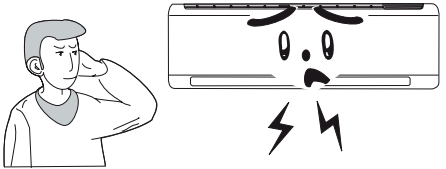
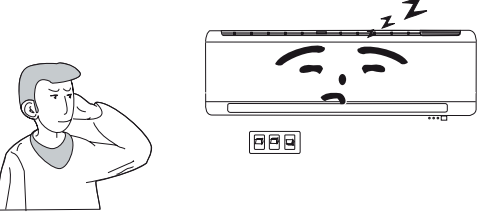
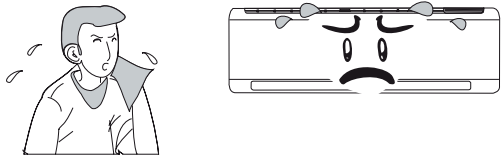
Problem	Solution
<p>An unusual odor is emitted from the outlet after operation is started.</p> 	<p>Clean the air filters (see page16). If the problem persists, the unit requires servicing. Please contact your authorized SANYO maintenance center.</p>
<p>Sounds of water flowing can be heard during operation.</p> 	<p>Occasionally there is a swooshing or gurgling sound when the air conditioner is started, stopped or when the compressor has started or stopped running. These sounds are due to refrigerant flowing and are not malfunctions.</p>
<p>Mist is emitted.</p> 	<p>When the indoor temperature and humidity are high, sometimes this phenomenon occurs. It is caused by the room air being swiftly cooled down. After running for a while, the indoor temperature and humidity will decrease, and the mist will disappear.</p>
<p>A creaking noise can be heard when starting or stopping the unit.</p> 	<p>This is caused by the deformation of plastic due to the change of temperature.</p>
<p>The unit will not operate.</p> 	<ul style="list-style-type: none"> <li>• Has the power been turned off?</li> <li>• Is the power plug loose?</li> <li>• Is the voltage too high or too low? (Please ask a qualified service representative to check the voltage.)</li> <li>• Has the TIMER ON function been correctly operated?</li> </ul>
<p>Cooling (Heating) efficiency is inadequate.</p> 	<ul style="list-style-type: none"> <li>• Is the temperature setting appropriate?</li> <li>• Are the inlet or outlet vents obstructed?</li> <li>• Is the filter dirty?</li> <li>• Are the windows and doors closed?</li> <li>• Is the fan speed set to low?</li> <li>• Are there any heat sources in the room?</li> </ul>

## 6. TROUBLESHOOTING

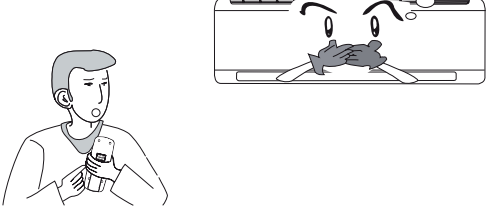
Problem	Solution
<p>Remote control unit does not work.</p> 	<ul style="list-style-type: none"> <li>• If the unit is experiencing abnormal interference or the functions are being changed too frequently, wireless remote control unit may not work properly. Pulling out and firmly re-inserting the power plug should reestablish normal operation.</li> <li>• Is the remote control unit pointed at the receiver? Is there any obstruction?</li> <li>• Check if the batteries in the control unit are correct; if not, insert the correct batteries.</li> </ul>
<p>There is water leakage from the indoor unit.</p>	<ul style="list-style-type: none"> <li>• The air humidity is on the high side.</li> <li>• Condensed water has overflowed.</li> <li>• The indoor unit drainage pipe connection is loose.</li> </ul>
<p>There is water leakage from the outdoor unit.</p>	<ul style="list-style-type: none"> <li>• When the unit is operating in COOL mode, condensation will form at the connection of pipe and pipe joint due to the water being cooled down.</li> <li>• When in "HEAT" or "Defrosting" mode, the ice has thawed and flowed out.</li> <li>• When in "HEAT" mode, water adhering to the heat exchanger has dripped off.</li> </ul>
<p>Noise is emitting from the indoor unit.</p>	<ul style="list-style-type: none"> <li>• This is a fan or compressor relay switching (On/OFF) sound.</li> <li>• When the unit is defrosting or has stopped running, sound will be emitted due to the refrigerant flowing in the opposite direction.</li> </ul>
<p>The indoor unit does not produce airflow.</p>	<ul style="list-style-type: none"> <li>• In HEAT "☀" mode and when the indoor heat exchanger's temperature is very low, the unit may stop generating wind in order to prevent the generation of cool wind (within 3 minutes).</li> <li>• In HEAT "☀" mode and when the outdoor temperature is very low or there is high humidity, the outdoor heat exchanger may be frosted. In such case, the unit will automatically start defrosting and the indoor unit fan stops blowing for 3 - 12 minutes. During defrosting, water may flow out of the unit or vapor may be produced.</li> <li>• In dehumidifying "💧" mode, the indoor fan sometimes stops in order to avoid recondensation.</li> </ul>
<p>Moisture forms on the air outlet vent.</p>	<ul style="list-style-type: none"> <li>• If the unit is operating in high humidity for long periods of time, moisture will condense on the air outlet grill and drip off.</li> </ul>

# **APPENDIX B** INSTALLATION INSTRUCTIONS

## **SAP-KRV9AEH + SAP-CRV9AEH SAP-KRV12AEH + SAP-CRV12AEH**

(II-852-6-4190-527-00-0)



## – Inverter Split System Air Conditioner –

COOL/DRY/HEAT Model

This air conditioner uses the new refrigerant R410A.

### Contents

	Page
<b>IMPORTANT!</b> <b>Please Read Before Starting .....</b>	<b>2</b>
<b>1. REQUIREMENTS FOR INSTALLATION .....</b>	<b>3</b>
1-1. Basic Requirements for Installation Location	
1-2. Indoor Unit Installation Position Selection	
1-3. Outdoor Unit Installation Position Selection	
1-4. Safety Requirements for Electrical Devices	
1-5. Grounding (Earthing) Requirements	
1-6. Type of Copper Tube and Insulation Material	
1-7. Other Wiring Considerations	
<b>2. INSTALLATION DIMENSION DIAGRAM.....</b>	<b>5</b>
<b>3. INSTALL INDOOR UNIT .....</b>	<b>6</b>
3-1. Install the Rear Panel	
3-2. Install the Tubing Hole	
3-3. Install the Drain Hose	
3-4. Connect the Indoor and Outdoor Wiring	
3-5. How to Install the Indoor Unit	
<b>4. INSTALL OUTDOOR UNIT .....</b>	<b>10</b>
4-1. Wiring Instructions for the Outdoor Unit	
4-2. Refrigerant Tubing	
4-3. Air Purging	
4-4. Tubing Length	
4-5. Outdoor Condensation Drainage	
4-6. Accessories	
<b>5. PUMP DOWN .....</b>	<b>16</b>
5-1. What is Pump Down?	
5-2. Pump Down Procedure	
<b>6. CHECK AFTER INSTALLATION AND TEST RUN.....</b>	<b>17</b>
6-1. Check After Installation	
6-2. Test Run	
<b>7. ELECTRIC WIRING SYSTEM .....</b>	<b>18</b>

### Model Combinations

Combine indoor and outdoor units only as listed below.

<u>Indoor Unit</u>	<u>Outdoor Unit</u>
SAP-KRV9AEH _____	SAP-CRV9AEH
SAP-KRV12AEH _____	SAP-CRV12AEH

Power Source:

50 Hz, single-phase, 220 – 240 VAC

### NOTE

The illustrations are based on the typical appearance of a standard model. Consequently, the shape may differ from that of the air conditioner that you are installing.

English

Español

Français

Deutsch

Italiano

Português

Ελληνικά

## IMPORTANT!

### Please Read Before Starting

This air conditioning system meets strict safety and operating standards. As the installer or service person, it is an important part of your job to install or service the system so it operates safely and efficiently.

**For safe installation and trouble-free operation, you must:**

- Carefully read this instruction booklet before beginning.
- Follow each installation or repair step exactly as shown.
- Observe all local, state, and national electrical codes.
- Pay close attention to all warning and caution notices given in this manual.



**WARNING**

This symbol refers to a hazard or unsafe practice which can result in severe personal injury or death.



**CAUTION**

This symbol refers to a hazard or unsafe practice which can result in personal injury or product or property damage.

#### If Necessary, Get Help

These instructions are all you need for most installation sites and maintenance conditions. If you require help for a special problem, contact our sales/service outlet or your certified dealer for additional instructions.

#### In Case of Improper Installation

The manufacturer shall in no way be responsible for improper installation or maintenance service, including failure to follow the instructions in this document.

### SPECIAL PRECAUTIONS

**WARNING**

#### When Wiring



**ELECTRICAL SHOCK CAN CAUSE SEVERE PERSONAL INJURY OR DEATH. ONLY A QUALIFIED, EXPERIENCED ELECTRICIAN SHOULD ATTEMPT TO WIRE THIS SYSTEM.**

- Do not supply power to the unit until all wiring and tubing are completed or reconnected and checked.
- Highly dangerous electrical voltages are used in this system. Carefully refer to the wiring diagram and these instructions when wiring. Improper connections and inadequate grounding can cause **accidental injury or death**.
- **Ground the unit** following local electrical codes.
- Connect all wiring tightly. Loose wiring may cause overheating at connection points and a possible fire hazard.
- Install a protective **leakage breaker** depending on the installation location (especially a damp or humid location). If a **leakage breaker** is not installed, electric shock can occur.

#### When Transporting

Be careful when picking up and moving the indoor and

outdoor units. Get a partner to help, and bend your knees when lifting to reduce strain on your back. Sharp edges or thin aluminum fins on the air conditioner can cut your fingers.

#### When Installing...

##### ...In a Ceiling or Wall

Make sure the ceiling/wall is strong enough to hold the unit's weight. It may be necessary to construct a strong wood or metal frame to provide added support.

##### ...In a Room

Properly insulate any tubing run inside a room to prevent "sweating" that can cause dripping and water damage to walls and floors.

##### ...In Moist or Uneven Locations

Use a raised concrete pad or concrete blocks to provide a solid, level foundation for the outdoor unit. This prevents water damage and abnormal vibration.

##### ...In an Area with High Winds

Securely anchor the outdoor unit down with bolts and a metal frame. Provide a suitable air baffle.

##### ...In a Snowy Area

- Position the outdoor unit in a protected location where snow will not blow into it.
- Install the outdoor unit on a raised platform that is higher than drifting snow. Provide snow vents.

#### When Connecting Refrigerant Tubing

- Use the flare method for connecting tubing.
- Apply refrigerant lubricant to the matching surfaces of the flare and union tubes before connecting them, then tighten the nut with a torque wrench for a leak-free connection.
- Check carefully for leaks before starting the test run.

#### When Servicing

- Turn the power OFF at the main power box (mains) before opening the unit to check or repair electrical parts and wiring.
- Keep your fingers and clothing away from any moving parts.
- Clean up the site after you finish, remembering to check that no metal scraps or bits of wiring have been left inside the unit being serviced.



**CAUTION**

#### Others

- Ventilate any enclosed areas when installing or testing the refrigeration system. Escaped refrigerant gas, on contact with fire or heat, can produce dangerously toxic gas.
- Confirm upon completing installation that no refrigerant gas is leaking. If escaped gas comes in contact with a stove, gas water heater, electric room heater or other heat source, it can produce dangerously toxic gas.

## 1. Requirements for Installation

### 1-1. Basic Requirements for Installation Location

Installation in any of the following locations may lead to a malfunction. If this is unavoidable, before beginning please contact our service center.

- (1) A location where a strong heat source, vapor or flammable gas, or any easily ignitable material is present.
- (2) A location where high-frequency waves are generated by radio equipment, welding equipment, or medical equipment, etc.
- (3) A location where salt spray is present, such as in coastal areas, or in a corrosive salt environment.
- (4) A location where sulfuric gas is present, such as may be generated by hot springs.
- (5) A location where oil mist is present in the air.
- (6) Any other location with unusual or potentially hazardous circumstances.

### 1-2. Indoor Unit Installation Position Selection

- (1) The air inlet and outlet vents should not be near any obstructions. Be sure that the discharged air can reach the entire room.
- (2) Select a location where water from condensation can easily drain to the outside, and where the indoor unit can be easily connected to the outdoor unit.
- (3) Select a location that cannot be easily reached by small children.
- (4) Select a location that will support the full weight of the unit, will be unaffected by vibration, and not result in increased noise levels.
- (5) Leave enough space to allow for routine maintenance. The height of the installation location should be 150 cm or more from the floor.
- (6) Install the indoor unit more than 1 meter away from any antenna or power lines or connecting wires used for television, radio, telephone, security system, or intercom. Electrical noise from any of these sources may affect operation.
- (7) Select a location where the air filter can be easily removed.
- (8) Confirm that the installation location and dimensions are in accordance with the dimensions in the installation diagram (page 5).

### 1-3. Outdoor Unit Installation Position Selection

- (1) Select a location where air discharge and operating noise will not bother the neighbors, nor harm animals or plants.
- (2) Select a location with adequate ventilation.
- (3) Select a location where there are no obstructions that can block the air intake and discharge vents.
- (4) Select a location that will support the full weight of the unit, will be unaffected by vibration, and permit safe installation.
- (5) Select a dry location, and do not expose the unit to direct sunlight or strong wind.
- (6) Confirm that the installation location and dimensions are in accordance with the dimensions in the installation diagram (page 5), and allow for adequate space for maintenance and repairs.
- (7) The height difference of the connected tubing must be within 5 m, and the length of the connected tubing must be within 10 m.
- (8) Select a location that cannot be easily reached by small children.
- (9) Select a location that does not block any passageway, and which does not cause a public eyesore.

#### 1-4. Safety Requirements for Electrical Devices

- (1) Use an independent circuit of the rated AC voltage exclusive of any other devices and only with the specified cable diameter.
- (2) Applicable voltage operating range: 198 – 264 VAC
- (3) Do not forcefully pull on the power cable or suspend it without adequate support, either horizontally or vertically.
- (4) Be sure to properly ground (earth) the device to a reliable grounding point in accordance with local electrical codes and using an approved grounding connector. All wiring should be done only by a professional electrician.

#### NOTE

- A surge protector should be installed in the exclusive circuit along with a correctly sized breaker switch.
- The breaker switch (thermal/magnetic type) must be of proper capacity to serve as protection against short circuit and power overload.
- (5) The minimum distance from the unit to any inflammable object or material is 1.5 m.

#### NOTE

- The power supply wiring must be correctly and tightly connected, with no internal short circuit or leakage.
- A wrong connection may result in a fire hazard or system misoperation.

#### 1-5. Grounding (Earthing) Requirements

- (1) This air conditioner is a Type 1 device and must be grounded (earthed) accordingly. Be sure to follow all local electrical codes.
- (2) The power supply circuit must include a safe and reliable ground. DO NOT connect the ground/earth wire to any of the following:
  - Gas pipe
  - Tap water pipe
  - Sewage pipe
  - Any other point that does not meet electrical codes.

#### 1-6. Type of Copper Tube and Insulation Material

If you wish to purchase these materials separately from a local source, you will need:

- (1) Deoxidized annealed copper tube for refrigerant tubing.
  - Cut each tube to the appropriate lengths +30 cm to 40 cm to dampen vibration between units.
- (2) Foamed polyethylene insulation for the specified copper tubes as required to precise length of tubing. Wall thickness of the insulation should be not less than 8 mm.
- (3) Use insulated copper wire for field wiring. Wire size varies with the total length of wiring. Refer to 3-4-1. Wiring Instructions for details.

Narrow Tube		Wide Tube	
Outer Dia.	Thickness	Outer Dia.	Thickness
6.35 mm	0.8 mm	9.52 mm	0.8 mm

#### 1-7. Other Wiring Considerations

- (1) Wire only in accordance with the methods given in this manual for both power and inter-unit signal control, and carefully following the circuit diagram affixed to the unit for each isolated component.
- (2) The type and rating of the fuse used should comply with the label on the controller or fuse device.
- (3) The external static pressure when testing is “0Mpa.”

## 2. Installation Dimension Diagram

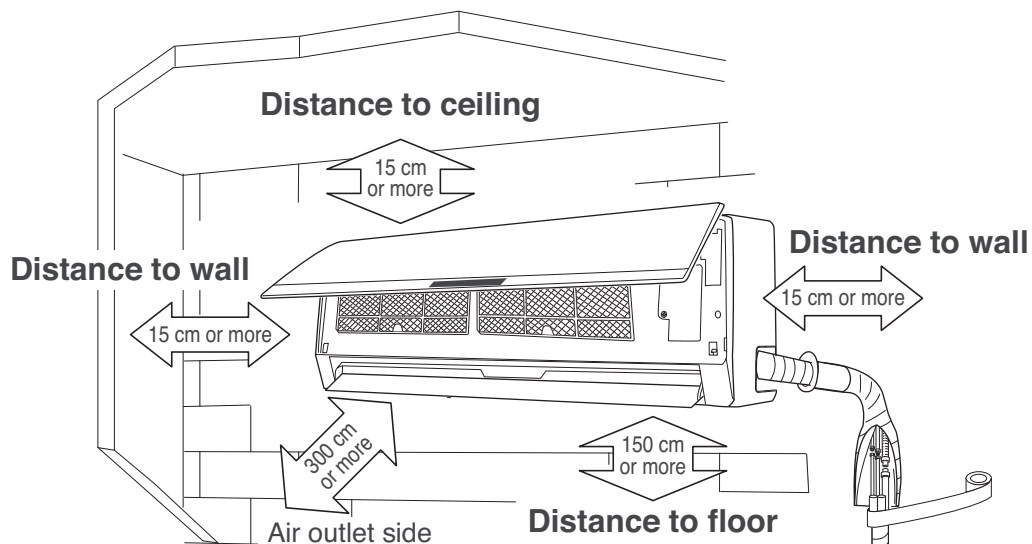

- The dimensions of the space necessary for correct installation of the appliance including the minimum permissible distances to adjacent structures.



**WARNING**

To prevent abnormal heat generation and the possibility of fire, do not place obstacles, enclosures, or grilles in front of or surrounding the air conditioner in a way that may block air flow.

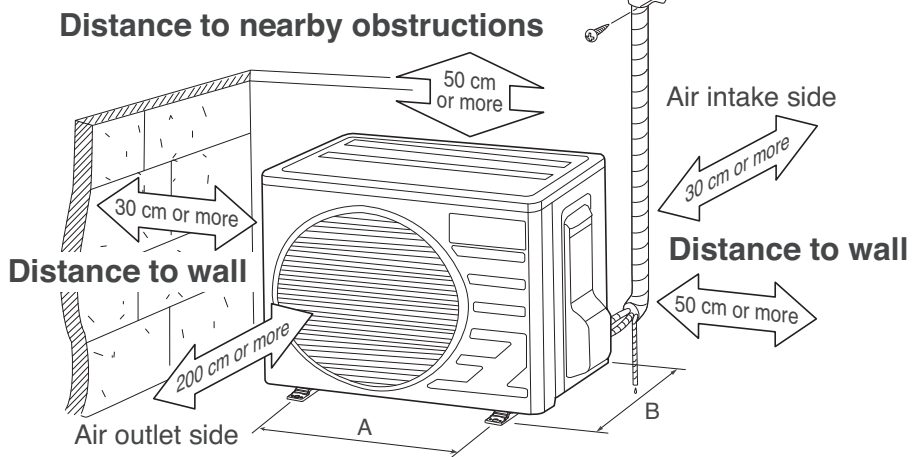

Outdoor Unit Installation Dimension		Model
A	B	
470 mm	299 mm	SAP-CRV9AEH
470 mm	299 mm	SAP-CRV12AEH

### 3. Install Indoor Unit

#### 3-1. Install the Rear Panel

- (1) Install the rear panel horizontally using a carpenter's level or inclinometer. Since the unit was designed for water drainage to either the left or right direction, depending on the outlet side you require provide a slight downward gradient to ensure adequate drainage of the water pan in the correct direction. (Fig. 11)
- (2) Fix the rear panel to the wall using screws required for the wall type. Use plaster board fasteners / toggle bolts for hollow walls.
- (3) Be sure to affix the rear panel securely enough to hold the weight on an adult (at least 60 kg), with attachment screws spaced to evenly divide the weight of the unit.

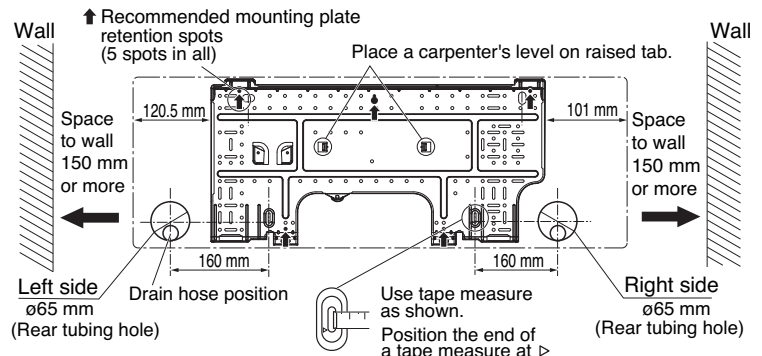

Fig. 11

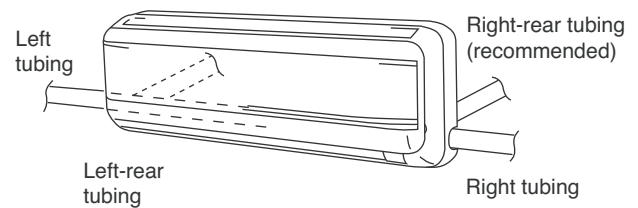

Fig. 12

#### 3-2. Install the Tubing Hole

- (1) Determine which side of the unit you should make the hole for tubing and wiring. (Fig. 12)
- (2) Make the tubing hole (ø65 mm) in the wall at a slight downward slant to the outdoor side. (Fig. 13)

#### NOTE

Before making the hole, check carefully that no studs or pipes are directly run behind the spot to be cut.



**CAUTION**

**Also avoid areas where electrical wiring or conduits are located.**

The above precautions are also applicable if tubing goes through the wall in any other location.

- (3) Insert a PVC pipe in the hole to prevent the connection piping and wiring from being damaged when passing through the hole.

#### 3-3. Install the Drain Hose

- (1) The drain hose must be angled at a downward slant for smooth, unimpeded drainage.
- (2) Supply adequate support for the hose, and do not pull on it or permit bends or water traps to occur. The outlet end must not be immersed in water or otherwise blocked. (Fig. 14)
- (3) When extending the drain hose inside a room, cover it with adequate insulation to prevent condensation and dripping. This is important to avoid damage to walls, floors, or room furnishings.

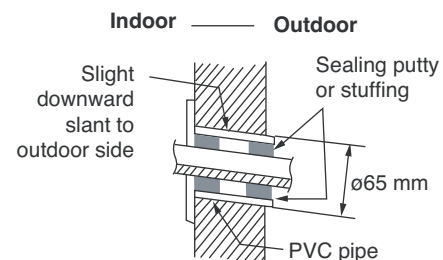

Fig. 13

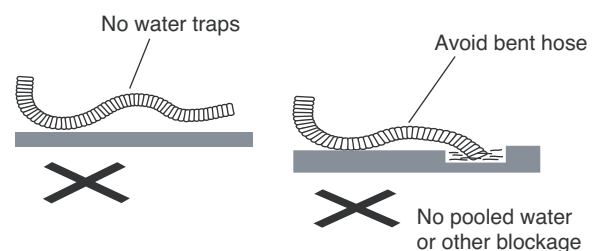

Fig. 14

### 3-4. Connect the Indoor and Outdoor Wiring



#### WARNING

To avoid the risk of fire hazard, be sure to consult your local dealer if additional wire length is required. A minimum wire thickness (gauge) is required, depending on the length used.

- (1) Grasp both ends of the front panel, and remove it by opening towards the front and pulling towards you.
- (2) Remove the screw on the right side cover and open the cover. (Fig. 15)
- (3) Insert the inter-unit wiring into the through-the-wall PVC pipe.
- (4) Route the inter-unit wiring from the back of the indoor unit and pull it towards the front for connection. (Fig. 16)
- (5) Connect the inter-unit wiring to the corresponding terminals on the terminal plate (Fig. 17) while referring to the wiring diagram.
- (6) Be sure to secure the wiring with the clamp. (Fig. 18)



#### WARNING

- Since one end of the power connector has been connected to the unit, when testing the unit with power supplied, be aware that the exposed end of the cable will carry a dangerous electrical charge. Before applying power, be sure to insulate the exposed end with electrician's tape to prevent short circuit or electrical shock.
- Loose wiring may cause the terminal to overheat or result in unit malfunction. A fire hazard may also exist. Therefore, be sure that all wiring is tightly connected.

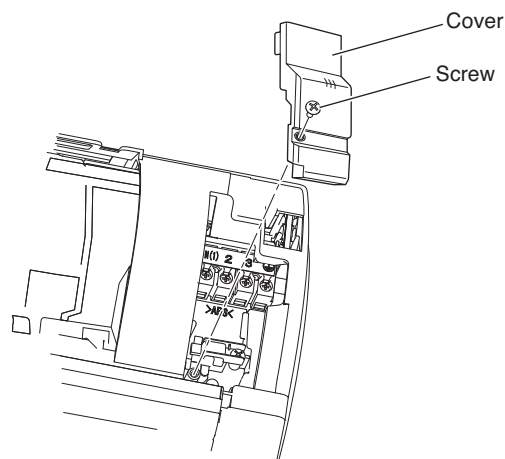

Fig. 15

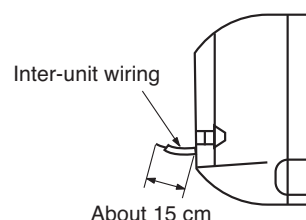

Fig. 16

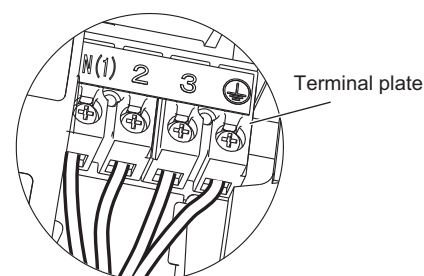

Fig. 17

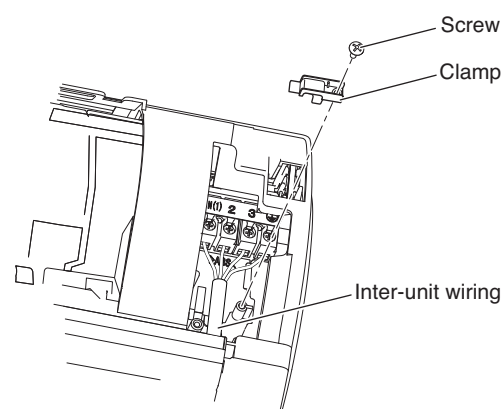

Fig. 18

#### 3-4-1. Wiring Instructions

##### General Precautions on Wiring

- (1) Before wiring, confirm the rated voltage of the unit as shown in the nameplate, then carry out the wiring closely following the wiring diagram.
- (2) Provide a power outlet to be used exclusively for each unit, with a power supply disconnect and circuit breaker for overcurrent protection provided in the exclusive line.
- (3) To prevent possible hazard due to insulation failure, the unit must be grounded.
- (4) Each wiring connection must be done tightly and in accordance with the wiring system diagram. Wrong wiring may cause the unit to misoperate or become damaged.
- (5) Do not allowed wiring to touch the refrigerant tubing, compressor, or any moving parts of the fan.
- (6) Unauthorized changes in the internal wiring can be very dangerous. The manufacturer will accept no responsibility for any damage or misoperation that occurs as a result of such unauthorized changes.

### 3-4-2. Wire Length and Diameter

Regulations on wiring diameter differ from locality to locality. For field wiring requirements, please refer to local electrical codes. Carefully observe these regulations when carrying out the installation.

Listed in the tables below are the recommended and maximum allowable wire lengths and diameters for the power supply system. Please refer to the wiring system diagram (Fig. 19) for the meaning of "A", "B", and "C" in Table 1.

Table 1

Cross-Sectional Area (mm <sup>2</sup> ) Model	(A) Power Supply Wiring Length (m) (B) Power Line Length (m)		(C) Control Line Length (m)	Fuse or Circuit Breaker Capacity
	(A) 1.5 mm <sup>2</sup>	(B) 1.5 mm <sup>2</sup>	1.5 mm <sup>2</sup>	
KRV9AEH	1.8 m	15.0 m	15.0 m	15A
KRV12AEH	1.8 m	15.0 m	15.0 m	



#### CAUTION

- Be sure to connect the power supply line to the indoor unit as shown in the wiring diagram. The outdoor unit draws its power from the indoor unit.
- Do not run wiring for antenna, signal, or power lines of television, radio, stereo, telephone, security system, or intercom any closer than 1 meter from the power cable and wires between the indoor and outdoor units. Electrical noise may affect the operation.

#### WIRING SYSTEM DIAGRAM

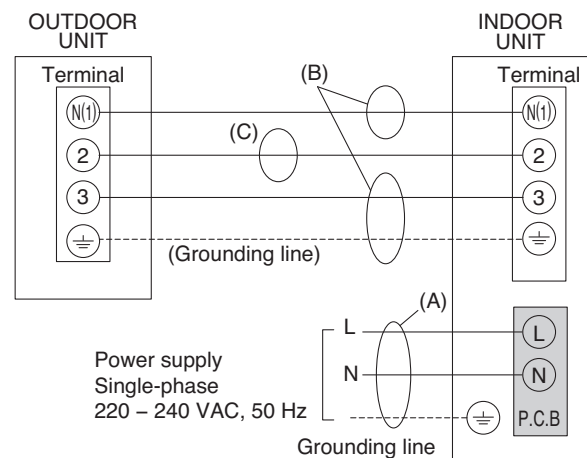

Fig. 19



#### WARNING

- Be sure to comply with local codes on running the wire from the indoor unit to the outdoor unit (size of wire and wiring method, etc.).
- Each wire must be firmly connected.
- No wire should be allowed to touch refrigerant tubing, the compressor, or any moving part.



#### WARNING

- To avoid the risk of electric shock, each air conditioner unit must be grounded.
- For the installation of a grounding device, please observe local electrical codes.
- Grounding is necessary, especially for units using inverter circuits, in order to release charged electricity and electrical noise caused by high tension. Otherwise, electrical shock may occur.
- Place a dedicated ground more than 2 meters away from other grounds and do not have it shared with other electric appliances.



### 3-5. How to Install the Indoor Unit

For tubing, choose either the left side or right side direction.

- (1) When routing the tubing and wiring from the left or right side of the indoor unit, cut out the knock-out hole from the chassis as necessary. (Fig. 20)
  - Cut out knock-out hole 1 when routing the wiring only.
  - Cut out knock-out hole 1 and knock-out hole 2 when routing both the wiring and tubing.
- (2) Take out the tubing from body case, wrap the tubing, electric wire and water pipe (if local codes allow) with tape and push them through the tubing hole. (Fig. 21)
- (3) Hang the mounting slots of the indoor unit on the upper tabs of the rear panel and check that it is securely seated on the rear panel. (Fig. 22)
- (4) Carefully bend the tubing (if necessary) to run along the wall in the direction of the outdoor unit and then tape as far as the fittings.
 

(See Caution on page 12). The drain hose should come straight down the wall to a point where water run-off won't stain the wall.
- (5) Connect the refrigerant tubing to the outdoor unit.
 

(After performing a leak test on the connecting part, insulate it with tubing insulation. (Fig. 21)

Also, refer to page 12, (connecting tubing between indoor and outdoor units).

#### NOTE

For stable operation of the air conditioner, do not install wall-mounted type indoor units less than 1.5 m from the floor level. (Fig. 23)

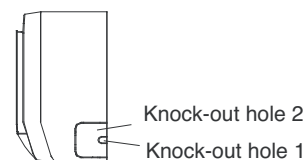

Fig. 20

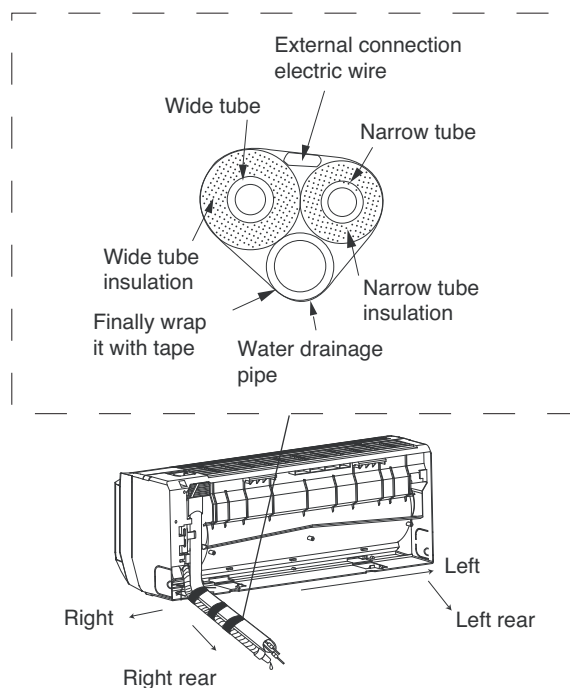

Fig. 21

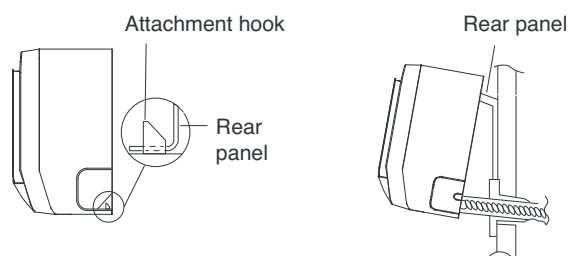

Fig. 22



**WARNING**

**Do not supply power to the system or operate it until all tubing and wiring to the outside unit are completed.**



**Risk of Electric Shock**

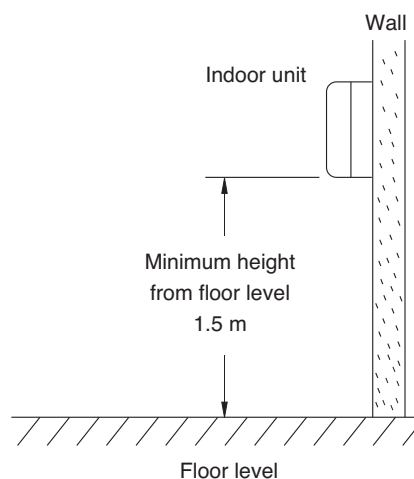

Fig. 23

## 4. Install Outdoor Unit

### 4-1. Wiring Instructions for the Outdoor Unit

Regulations on wire size differ from locality to locality. For field wiring requirements, please refer to your local electrical codes. Make sure that the installation fully complies with all local and national regulations.

- (1) Disassemble the handle on the outdoor unit right side plate. (Screw x 1pc)
- (2) Take off the wire clamp, then connect and fix the power connect cord to the terminal of the line bank. Connect the inter-unit wiring and power line according to the drawing on the handle.
- (3) Be sure to secure the wiring with the clamp. (Fig. 24a)

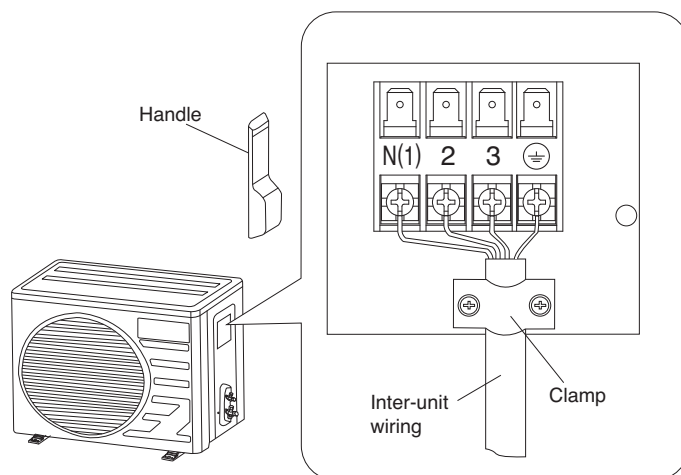

Fig. 24a

#### NOTE

Use the wire clamp to fix the signal control wire, then connect to the corresponding connector.

- (4) Be sure to size each wire allowing approx. 10 cm longer than the required length for wiring. Store excess wiring inside the cabinet.
- (5) When connections are completed, check that all connections are correct as shown in the wiring system diagram on the handle.
- (6) Be sure to ground the unit according to your local codes.
- (7) Reinstall the handle. (Screw x 1pc)

### How to connect wiring to the terminal

#### a) For Indoor Unit

- (1) Cut the wire end with a cutting pliers, then strip the insulation to expose the wire about 7 mm. See the label (Fig. 24b) near the terminal plate.
- (2) Using a screwdriver, loosen the terminal screw on the terminal plate.
- (3) Insert the wire and tighten the terminal screw completely using a screwdriver.

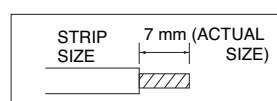

Fig. 24b

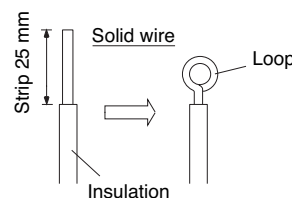

Fig. 24c

#### b) For Outdoor Unit

##### ■ For solid core wiring (or F-cable)

- (1) Cut the wire end with a cutting pliers, then strip the insulation to expose the solid wire about 25 mm. (Fig. 24c)
- (2) Using a screwdriver, remove the terminal screw(s) on the terminal plate.
- (3) Using the pliers, bend the solid wire to form a loop suitable for the terminal screw.
- (4) Shape the loop wire properly, place it on the terminal plate and fix it securely with the removed terminal screw using a screwdriver.

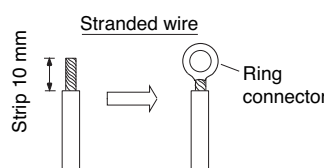

Fig. 24d

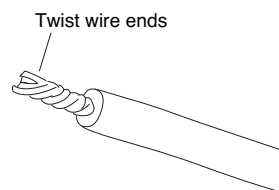

Fig. 24e

##### ■ For stranded wiring

- (1) Cut the wire end with a cutting pliers, then strip the insulation to expose the stranded wiring about 10 mm and tightly twist the wire ends. (Figs. 24d and 24e)
- (2) Using a screwdriver, remove the terminal screw(s) on the terminal plate.
- (3) Using a ring connector fastener or pliers, securely clamp each stripped wire end with a ring connector. (Fig. 24d)
- (4) Place the ring connector wire, and replace and tighten the removed terminal screw using a screwdriver. (Fig. 24f)

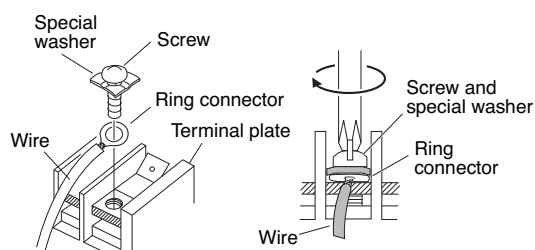

Fig. 24f

## 4-2. Refrigerant Tubing

### 4-2-1. Use of the Flaring Method

Many of the conventional split system air conditioners employ the flaring method to connect the refrigerant tubes that run between indoor and outdoor units. In this method, the copper tubes are flared at each end and connected with flare nuts.

### 4-2-2. Flaring Procedure with a Flare Tool

- Cut the copper tube to the required length with a tube cutter. It is recommended to cut approx. 30 – 50 cm longer than the tubing length you estimate.
- Remove burrs at the end of the copper tube with a reamer or file. This procedure is important and should be done carefully to make a good flare. (Fig. 25)

#### NOTE

When reaming, hold the tube end downward and be sure that no copper scraps fall into the tube. (Fig. 26)

- Remove the flare nut from the unit and be sure to mount it on the copper tube before making the flare.
  - Make a flare at the end of copper tube with a flare tool.\* (Figs. 27a and 27b)
- (\*Use "RIDGID" or equivalent.)

#### NOTE

A good flare should have the following characteristics:

- inside surface is glossy and smooth.
- edge is smooth.
- tapered sides are of uniform length.

### 4-2-3. Caution Before Connecting Tubes Tightly

- Be sure to apply a sealing cap or waterproof tape to prevent dust or water from getting into the tubes before they are used.
- Be sure to apply refrigerant lubricant to the matching surfaces of the flare and union before connecting them together. This is effective for reducing gas leaks. (Fig. 28)
- For proper connection, align the union tube and flare tube straight with each other, then screw in the flare nut lightly at first to obtain a smooth match. (Fig. 29)

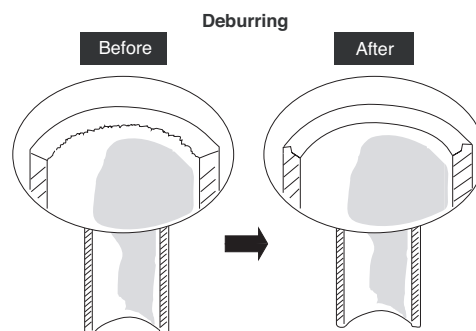

Fig. 25

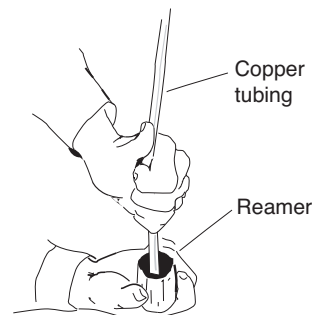
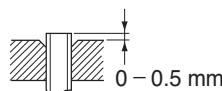
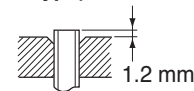

Fig. 26

If the special R410A flare tool is used:



If the previous flare tool (clutch-type) is used:



Adjust so that the amount of tube protrusion is as shown in the figure.

Fig. 27a

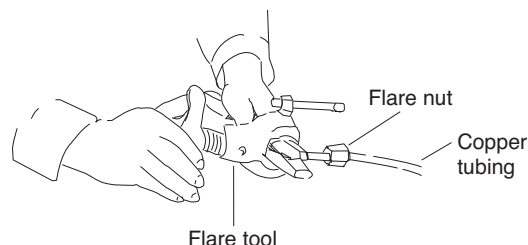

Fig. 27b

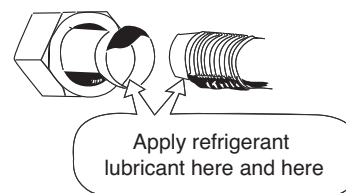

Fig. 28

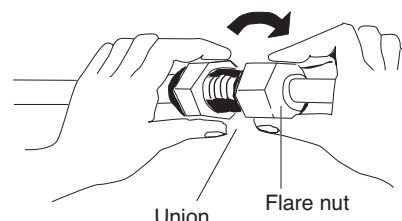

Fig. 29

#### 4-2-4. Connecting Tubing between Indoor and Outdoor Units

- Tightly connect the indoor side refrigerant tubing extended from the wall with the outdoor side tubing. (Fig. 30)
- To fasten the flare nuts, apply specified torque as:

**Table 2**

Tube Dia.	Tightening Torque
6.35 mm	14 – 18 N·m (140 – 180 kgf · cm)
9.52 mm	34 – 42 N·m (340 – 420 kgf · cm)
12.70 mm	49 – 61 N·m (490 – 610 kgf · cm)
15.88 mm	68 – 82 N·m (680 – 820 kgf · cm)

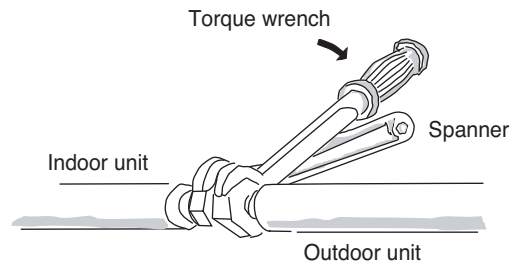

**Fig. 30**

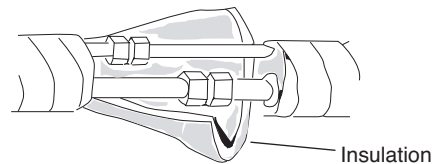

**Fig. 31**

#### 4-2-5. Insulation of Refrigerant Tubing

##### IMPORTANT

To prevent heat loss and wet floors due to dripping of condensation, **both tubes must be well insulated with a proper insulation material.** The thickness of the insulation should be a min. 8 mm. (Figs. 31 and 32)



##### CAUTION

**After a tube has been insulated, never try to bend it into a narrow curve, as this may cause it to break or crack.**

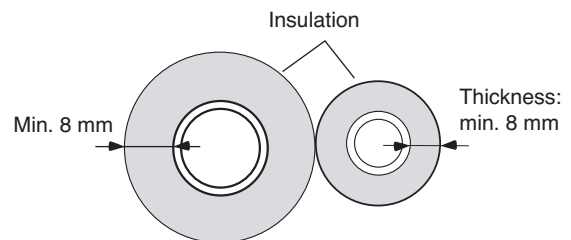

**Fig. 32**

#### 4-2-6. Taping the Tubes

- At this time, the 2 refrigerant tubes (and electrical wire if codes permit) should be taped together with armoring tape. The drain hose may also be taped together as 1 bundle with the tubing.
- Wrap the armoring tape from the bottom of the outdoor portion to the top of tubing where it enters the wall. As you wrap the tubing, overlap half of each previous tape turn. (Fig. 33)
- Clamp the tubing bundle to the wall, using 1 clamp approx. every 120 cm.

##### NOTE

Do not wind the armoring tape too tightly, since this will decrease the heat insulation effect. Also, be sure the condensation drain hose splits away from the bundle and drips clear of the unit and the tubing.

#### 4-2-7. Finish the Installation

After finishing insulating and taping over the tubing, use sealing putty to seal off the hole in the wall to prevent rain and draft from entering. Fig. 34 shows refrigerant tubing taped separately from the drain hose.

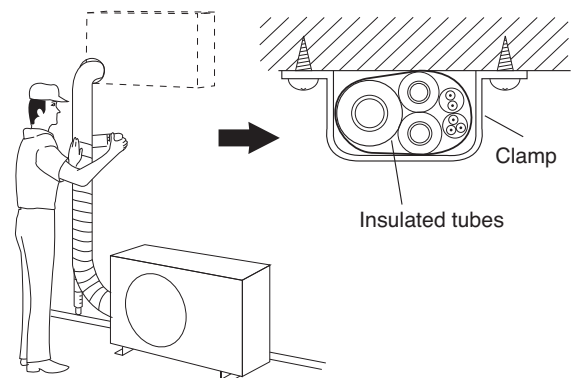

**Fig. 33**

Apply putty here

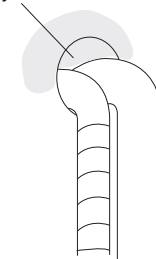

Tubing

**Fig. 34**

### 4-3. Air Purging

Air and moisture remaining in the refrigerant system have undesirable effects as indicated below. Therefore, they must be purged completely.

- Pressure in the system rises
- Operating current rises
- Cooling (or heating) efficiency drops
- Moisture in the air may freeze and block capillary tubing
- Water may lead to corrosion of parts in the refrigerant system

#### Air Purging With a Vacuum Pump (for Test Run)

- (1) Check that each tube (both narrow and wide tubes) between the indoor and outdoor units have been properly connected and all wiring for the test run has been completed. Note that both narrow and wide tube service valves on the outdoor unit are kept closed at this stage.
- (2) Using an adjustable wrench or box wrench, remove the valve caps from the service on both the narrow and wide tubes.
- (3) Connect a vacuum pump and a manifold valve (with pressure gauges) to the service port on the wide tube service valve. (Fig. 35)



#### CAUTION

- **The service port on the wide tube service valve uses a Schrader core valve to access the refrigerant system. The valve core is similar to those used in automobile tires. Therefore, be sure to use a vacuum hose connector which has a push-pin inside.**
- **Be sure to use a manifold valve for air purging. If it is not available, use a stop valve for this purpose. The “Hi” knob of the manifold valve must always be kept closed.**

- (4) With the “Lo” knob of the manifold valve open, run the vacuum pump. The operation time for the vacuum pump varies with tubing length and the capacity of the pump. The following table shows the amount of time for evacuation:

**Table 3**

Required time for evacuation when capacity of 100 liter/h vacuum pump is used	
If tubing length is less than 10 m	If tubing length is more than 10 m
10 min. or more	15 min. or more

#### NOTE

The required time in Table 3 is calculated based on the assumption that the ideal (or target) vacuum condition is around 10 mmHg abs.

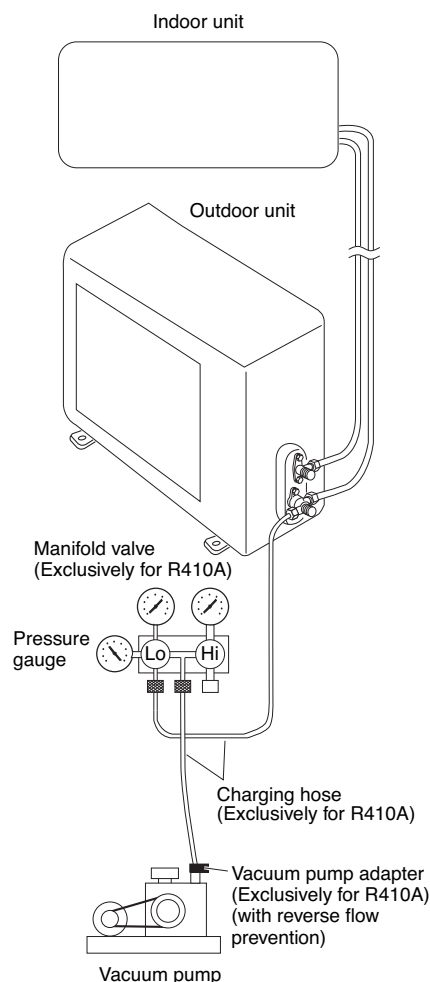

**Fig. 35**

#### NOTE

- To prevent other refrigerants from being mistakenly charged to units which use R410A, the size of the charge port on the service valve is different from the one for other refrigerant types. For servicing such as recharging, the specified charging hose, manifold, and vacuum pump adapter (with reverse flow prevention) for R410A must be used.

- (5) With the vacuum pump still running, close the "Low" knob of the manifold valve. Then stop the vacuum pump.
- (6) With the accessory hex wrench, turn the valve stem on the narrow tube service valve counter-clockwise by 90 degrees (1/4 turn) for 10 seconds, and then turn the stem clockwise to close it again. (Fig. 36)



**CAUTION**

**Be sure completely insert the hex wrench before attempting to turn the valve.**

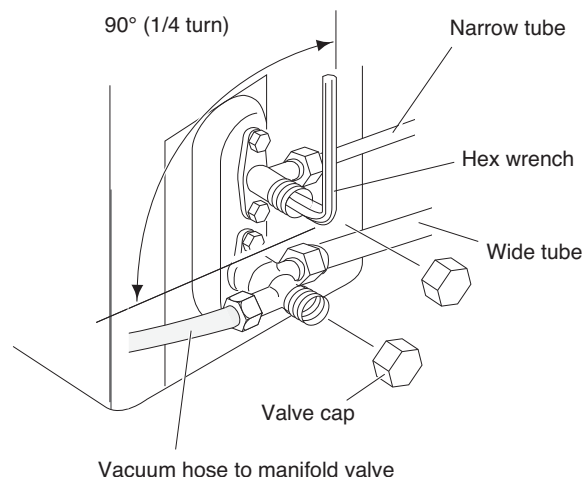

**Fig. 36**

- (7) Leak test all tubing joints (both indoor and outdoor) with liquid soap. Bubbles indicate a leak. Be sure to wipe off the soap with a clean cloth.
- (8) With the hex wrench, turn the wide tube service valve stem counter-clockwise to fully open the valve.
- (9) Turn the narrow tube service valve stem counter-clockwise to fully open the valve.
- (10) Loosen the vacuum hose connected to the wide tube service port slightly to release the pressure. Then remove the hose.



**CAUTION**

**This may cause the refrigerant gas to leak. In order to avoid this, take off the hose quickly.**

- (11) Fasten the valve cap on the wide tube service port securely with an adjustable wrench or box wrench. Next, mount the valve cap on the service valve and tightened it to 20 N·m (200 kgf·cm) with a torque wrench. This process is very important to prevent gas leaking from the system.
- (12) Test run the air conditioner. (See page 17)
- (13) While the air conditioner is running, apply liquid soap to check for any gas leaks around the service valves or caps.
- (14) If there is no leakage, stop the air conditioner.
- (15) Wipe off the soap on the tubing.

**This completes air purging with a vacuum pump and the air conditioner is ready for actual operation.**

#### 4-4. Tubing Length

Install unit within the maximum elevation different (H) above or below the outdoor unit and within a total tubing length (L) from the outdoor unit as detailed in Table 4 and Fig. 37.

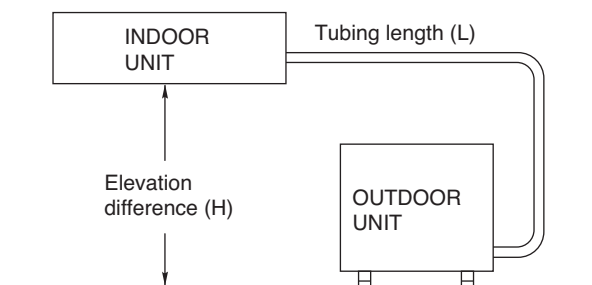

Fig. 37

Table 4

Model	Max. Allowable Tubing Length at Shipment (m) <sup>*1</sup>	Limit of Tubing Length (L) (m)	Limit of Elevation Different (H) (m)	Required Amount of Additional Refrigerant (g/m) <sup>*2</sup>
CRV9AEH	5.0	15	5	20
CRV12AEH	5.0	15	5	20

\*1 Standard tubing length is 5 m.

\*2 If total tubing length becomes 5 m to 15 m, charge additional refrigerant (R410A) by 20 g/m.

No additional charge of compressor oil is necessary.

#### 4-5. Outdoor Condensation Drainage

The drain hole at the bottom of the outdoor unit was not plugged at the time of factory shipment. If necessary, mount the accessory drain elbow before installing the outdoor unit. (Fig. 38)



**CAUTION**

**When installing in a cold area where drainage water may freeze, do not attach the provided drain elbow to the bottom plate of the unit.**

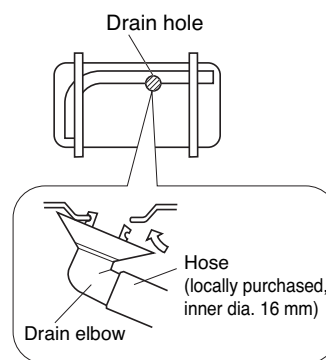

Fig. 38

#### 4-6. Accessories

Table 5 lists the accessories supplied with the unit.

Table 5

Parts	Figure	Q'ty	Parts	Figure	Q'ty	Parts	Figure	Q'ty
Remote control unit		1	AAA alkaline battery		2	Tapping screw		5
Flare nut		1	Drain elbow *		1	Insulation tube		1
Putty		1						

\* Packed in the outdoor unit

## 5. Pump Down

### 5-1. What is Pump Down?

Pump down means collecting all refrigerant gas in the system back into the outdoor unit without losing any gas. Pump down is used when the unit is to be moved or before servicing the refrigerant circuit.

### 5-2. Pump Down Procedure

#### NOTE

Be sure to carry out pump down with the unit in Cooling mode.

- (1) Connect the Lo side charging hose of the manifold valve to the service port on the wide tube service valve. (Fig. 39)
- (2) Using a hex wrench, turn the narrow tube service valve clockwise all the way to close the service valve (Fig. 40). (Be sure to confirm that the wide tube service valve is fully open.)
- (3) Press the ON/OFF button and start cooling operation.
- (4) When the low pressure gauge reading falls from 1 to 0.5 kg/cm<sup>2</sup>, fully close the wide tube valve stem (Fig. 41). Then quickly stop the unit.
- (5) Disconnect all gauges and hoses, and replace the valve caps as they were before.

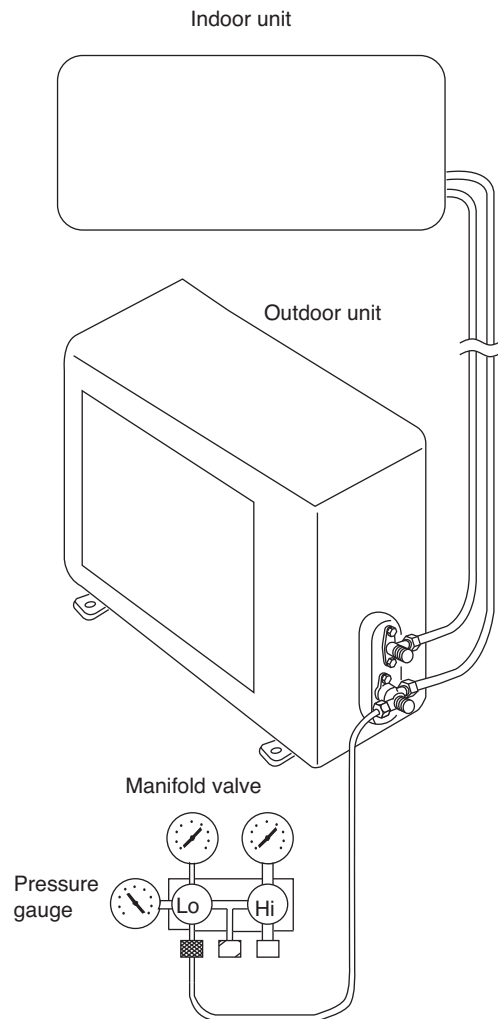

Fig. 39

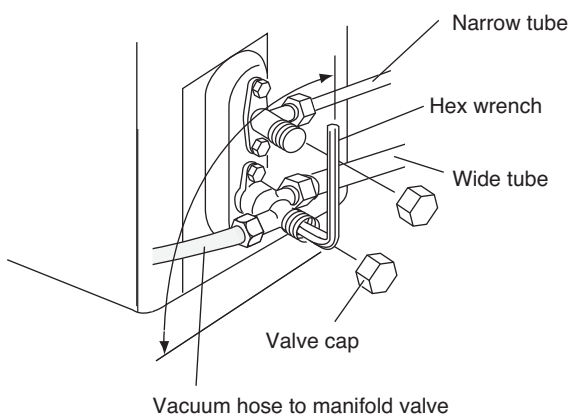

Fig. 41

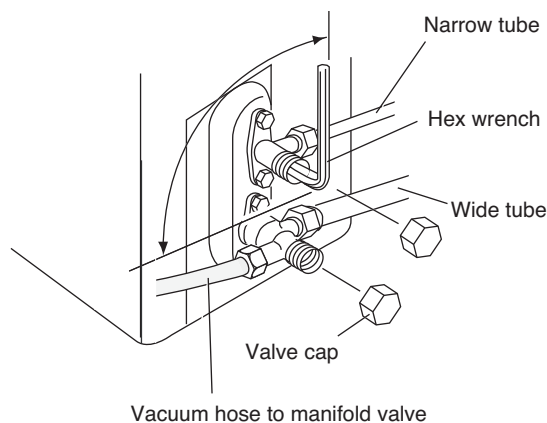

Fig. 40



## 6. Check After Installation and Test Run

### 6-1. Check After Installation

Check the items listed in the table below after installing the air conditioner.

Items to be checked	Possible malfunction
• Has it been securely mounted?	• The unit may fall over, shake, or emit noise.
• Have you done the refrigerant leakage test?	• It may have insufficient cooling (heating) capacity.
• Is heat insulation sufficient?	• It may cause condensation and dripping.
• Is water drainage adequate?	• It may cause condensation and dripping.
• Is the voltage in accordance with the rated voltage marked on the nameplate?	• It may cause electrical malfunction or system damage.
• Is the electric wiring and tubing connection installed correctly and securely?	• It may cause electrical leakage or shorting.
• Has the unit been connected to a secure ground connection?	• It may cause electrical malfunction or system damage.
• Is the power cord as specified?	• It may cause electrical malfunction or system damage.
• Is the air intake or outlet covered or blocked?	• It may cause of insufficient cooling (heating) capacity.
• Have the lengths of the connection tubing and refrigerant capacity been recorded?	• The refrigerant amount may not be correct.

### 6-2. Test Run

#### 6-2-1. Before Test Run

- Do not switch on the power before installation is finished completely.
- Electric wiring must be connected correctly and securely.
- Cut-off valves of the connection tubing should be opened.
- All foreign material such as wire bits and filings must be cleared from the unit.

#### 6-2-2. Test Run Method

- Switch on the power, then press the "ON/OFF" button on the wireless remote controller to start operation.
- Press the MODE button to select COOL, HEAT, or FAN to check whether operation is normal or not.

# 7. Electric Wiring System

## SISTEMA DE CONEXIONES ELÉCTRICAS

### Schéma de câblage électrique

### Elektrischer Schaltplan

### Impianto elettrico

### Sistema de fiação elétrica

### Ηλεκτρικό Ηύστημα Καλωδίωσης

Indoor Unit : SAP-KRV9/12AEH  
 Unidad interior : SAP-KRV9/12AEH  
 Appareil intérieur : SAP-KRV9/12AEH  
 Innenraumgerät : SAP-KRV9/12AEH

Unità Interna : SAP-KRV9/12AEH  
 Unidade interior : SAP-KRV9/12AEH  
 Εσωτερική μονάδα : SAP-KRV9/12AEH

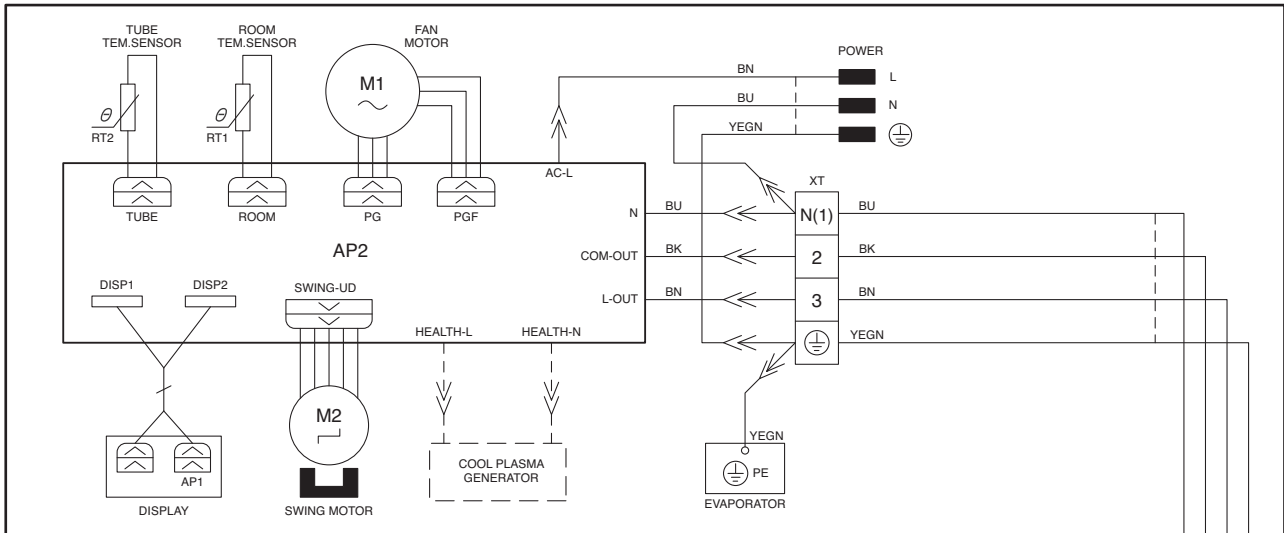

Outdoor Unit : SAP-CRV9/12AEH  
 Unidad exterior : SAP-CRV9/12AEH  
 Appareil extérieur : SAP-CRV9/12AEH  
 Außengerät : SAP-CRV9/12AEH

Unità Esterna : SAP-CRV9/12AEH  
 Unidade exterior : SAP-CRV9/12AEH  
 Εξωτερική μονάδα : SAP-CRV9/12AEH

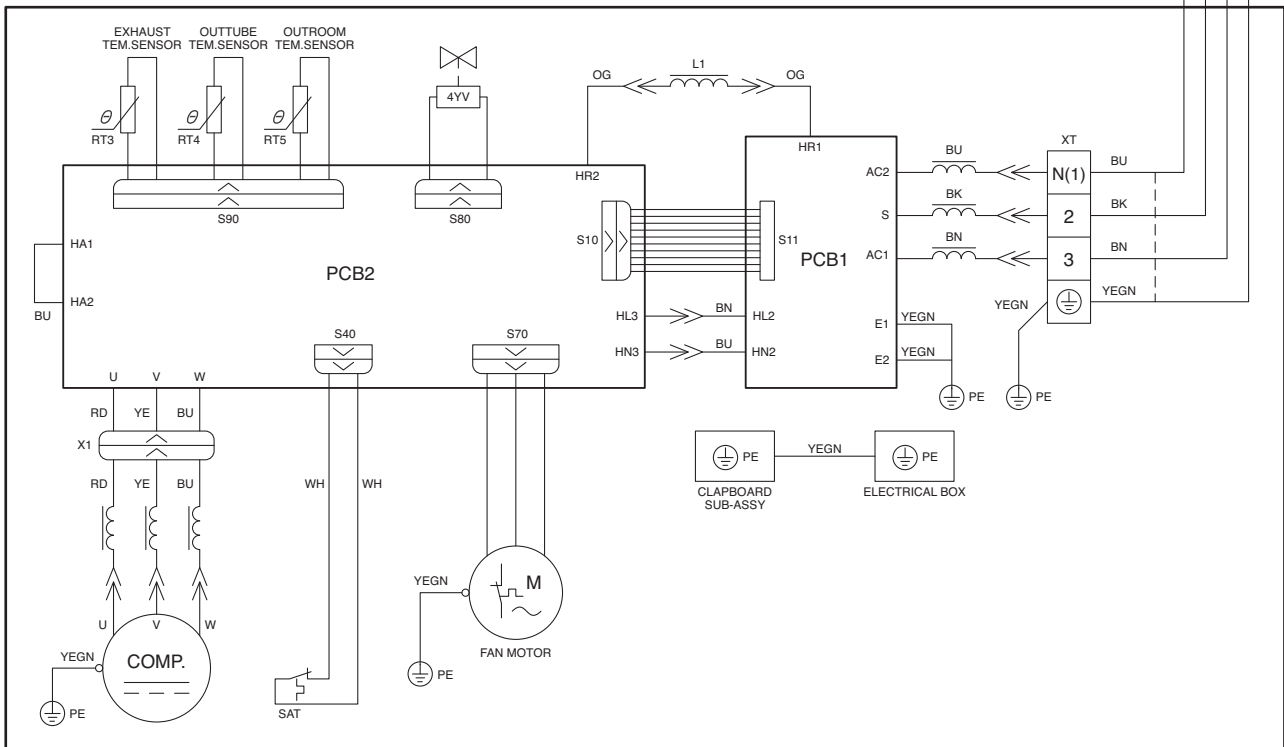





SANYO Electric Co., Ltd.  
Osaka, Japan  
June / 2010  
Printed in Japan (B)